

ASSEMBLY GUIDE

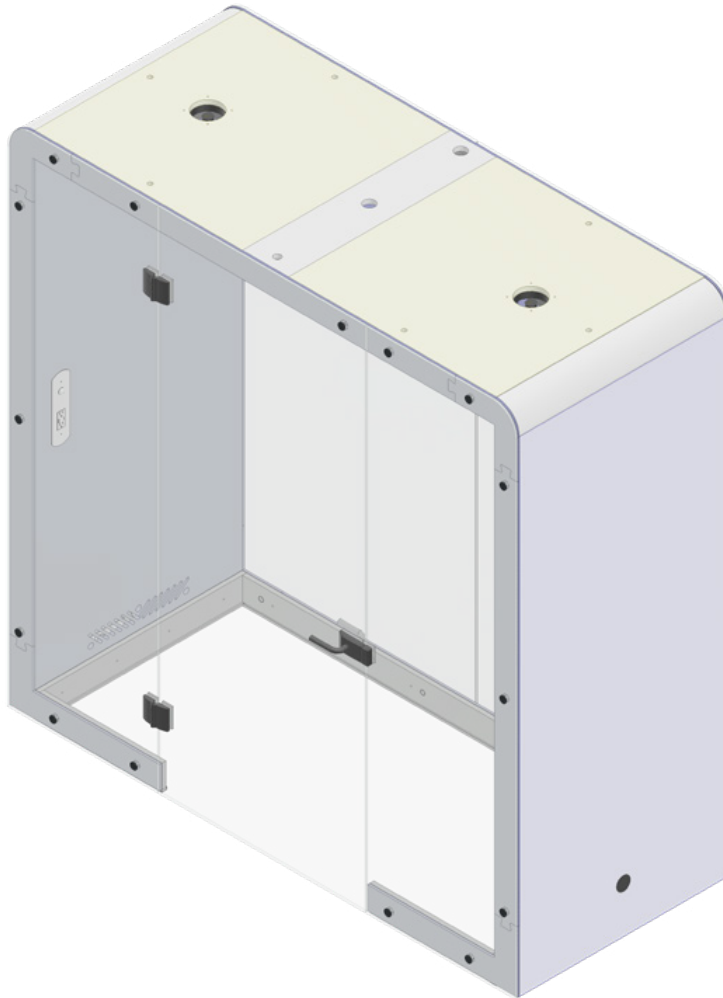

Kme Plus Floorless



FS201 x 30
Euro screw



FS203 x 48
Self tapping screw



FS205 x 6
Wood screw



FS208 x 18
M10 machine screw

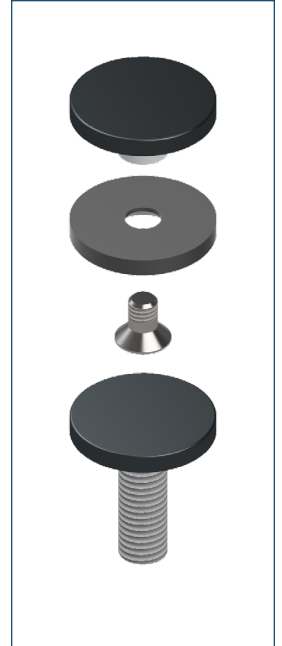

FS212 x 2
Door magnet set

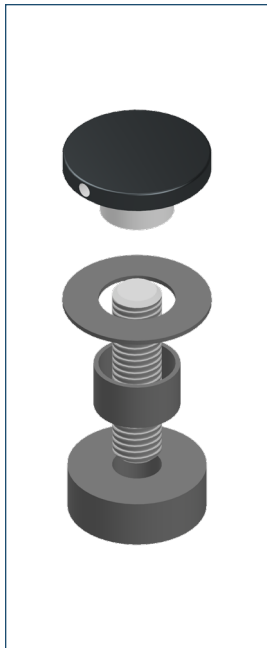

FS213 x 28
M10 stand-off cap set



FS218 x 8
M10 steel hex nut



FS219 x 8
Plastic cap



FS220 x 16
Self tapping screw

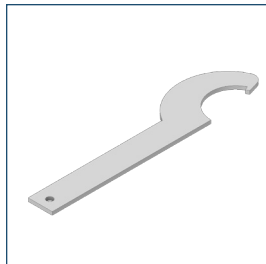

Stand-off cap key
x 2

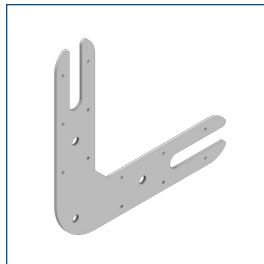

ST335 x 4
Units assembly
corner bracket

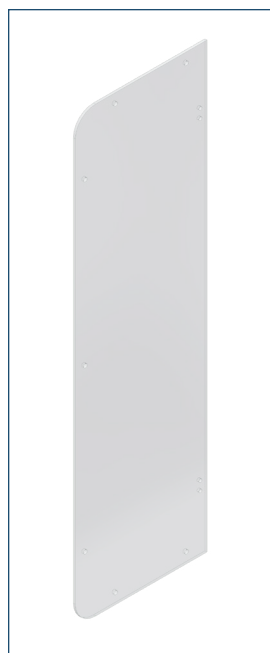

GL321 x 1
Hinges side of the front glass panel

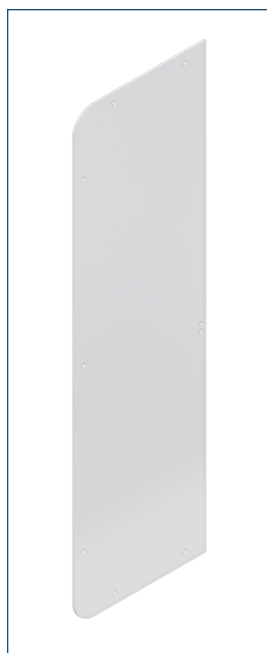

GL322 x 1
Receiving side of the front glass panel

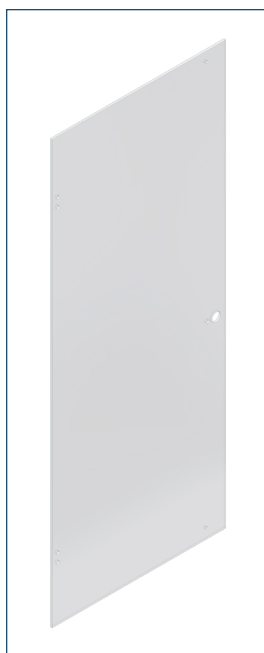

GL323 x 1
Glass door

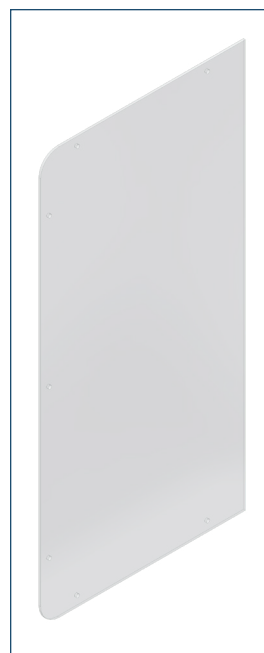

GL324 x 2
Rear glass panel

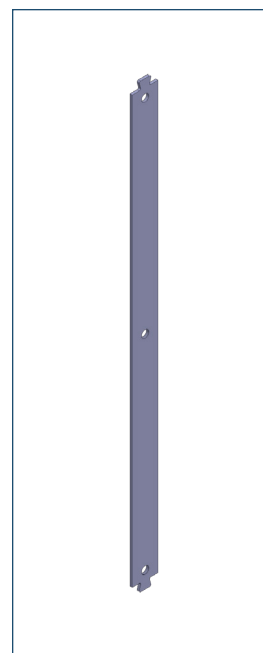

FT304 x 4
Acoustic cladding

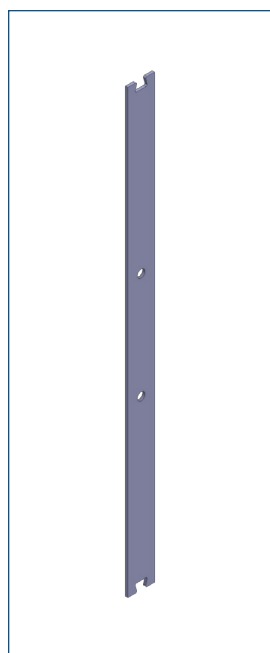

FT307 x 2
Acoustic cladding

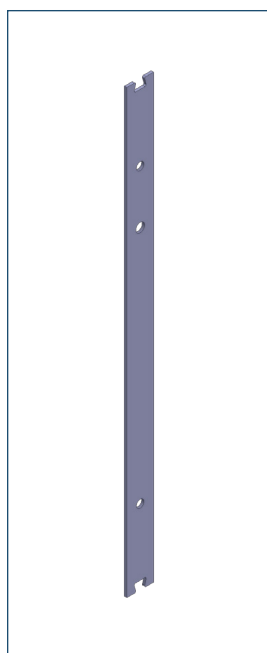

FT308 x 1
Acoustic cladding

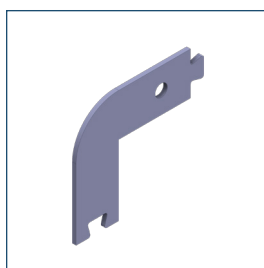

FT301 x 4
Acoustic cladding

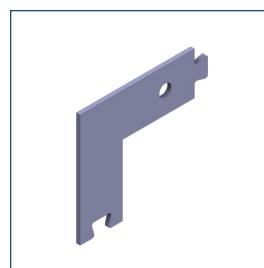

FT309 x 2
Acoustic cladding

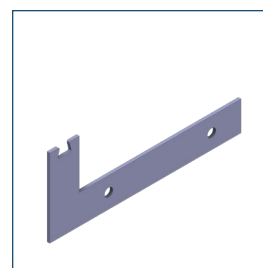

FT314 x 2
Acoustic cladding

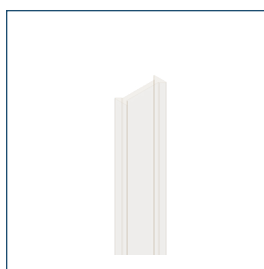

GA203 x 1
Butt glass gasket

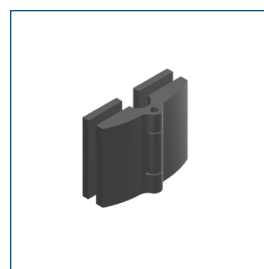

A_HW203 x 2
Door hinge x 2

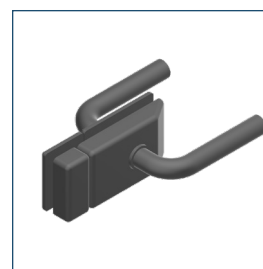

A_HW301 x 1
Door handle x 1

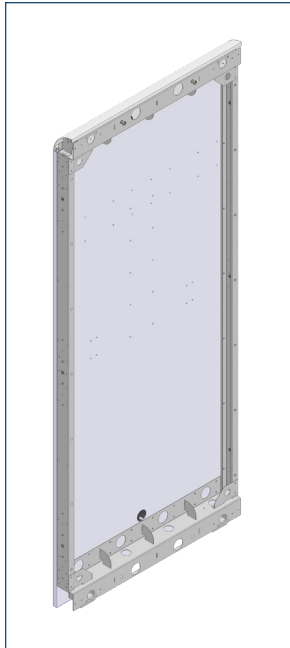

U_WL312 x 2
Wall unit

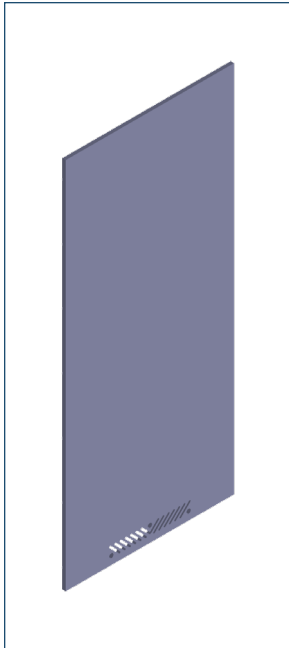

A_IN301 x 1
Acoustic interior panel

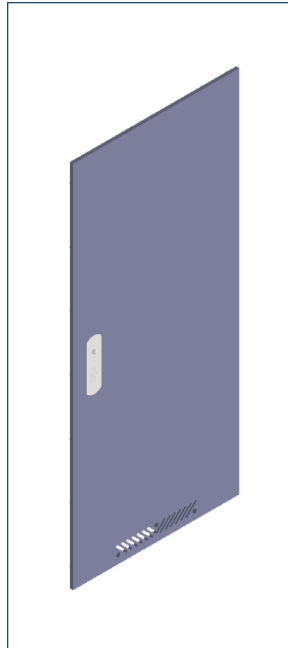

A_IN312 x 1
Acoustic interior panel

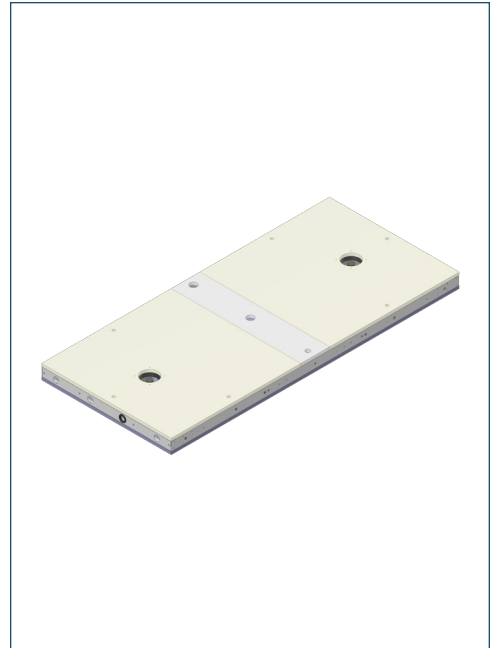

U_CL302 x 1
Ceiling unit

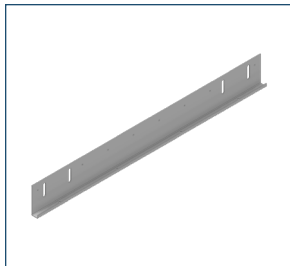

ST341 x 4
Base adjusted skirt L36"

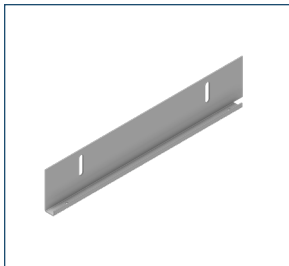

ST345 x 1
Base adjusted skirt L22"
(left)

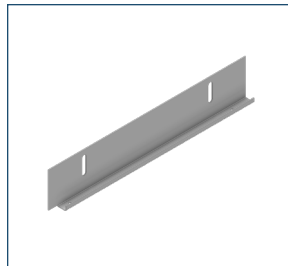

ST345 x 1
Base adjusted skirt L22"
(right)

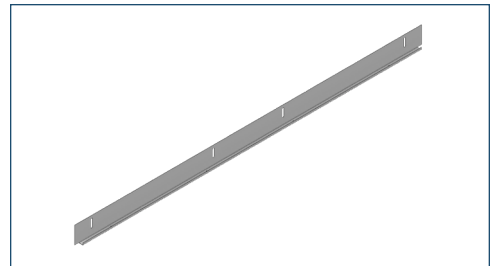

ST346 x 1
Base adjusted skirt L80"

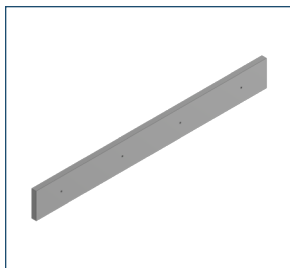

BB301 x 2
Decorative baseboard
L36"

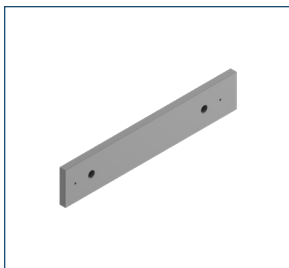

BB305 x 2
Decorative baseboard
L22"



BB311
Decorative 'skirt' trim
to be cut on site

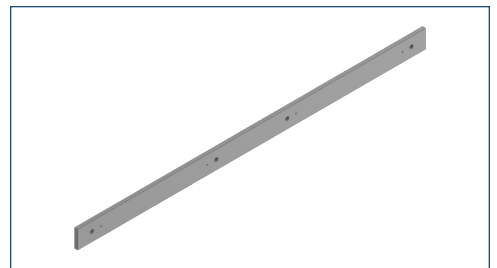

BB306 x 1
Decorative baseboard L80"

Intro (assembly scenario)

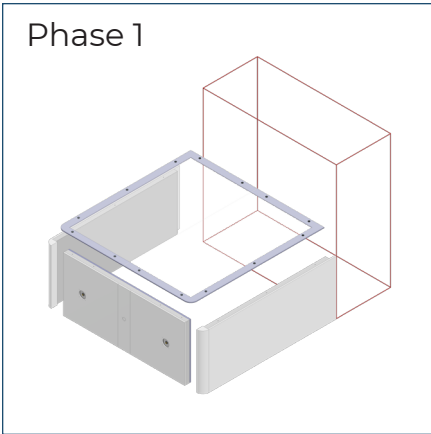

Rear segment assembly lay out on the ground. Remove acoustic interior panels

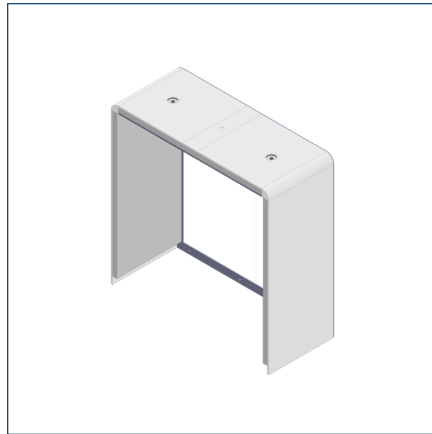

Raise up vertically assembled segment and locate properly

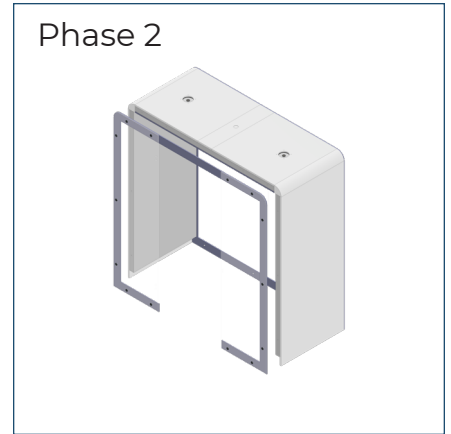

Assemble front glass panels
Level the unit

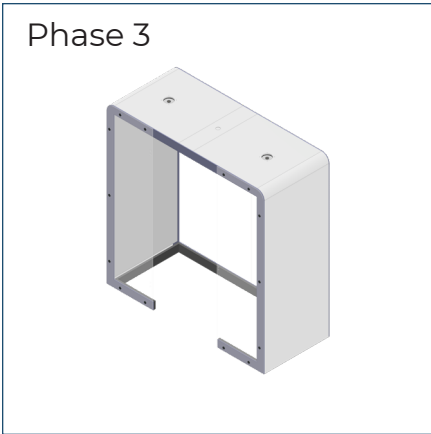

Complete base board assembly
Anchor to floor

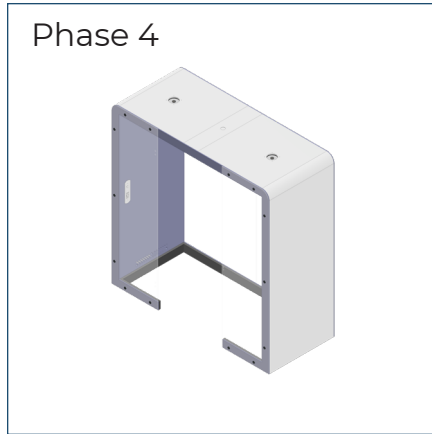

Cross connect the wires
Place roof panels on top
Attach acoustic interior panels

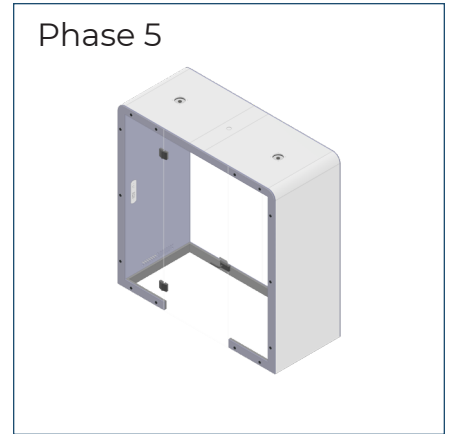

Assemble front glass door
Clean product

Wall units preparation

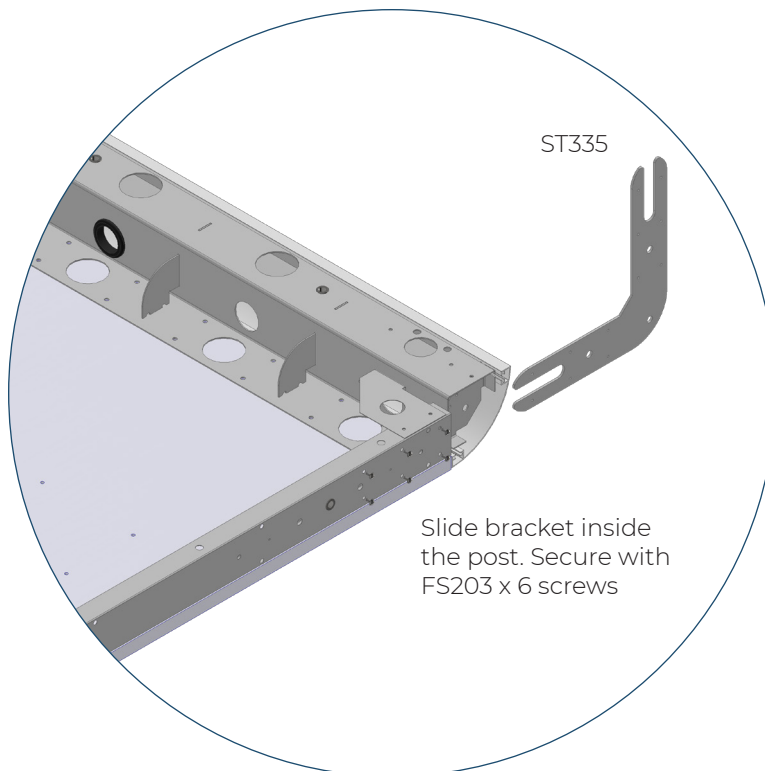
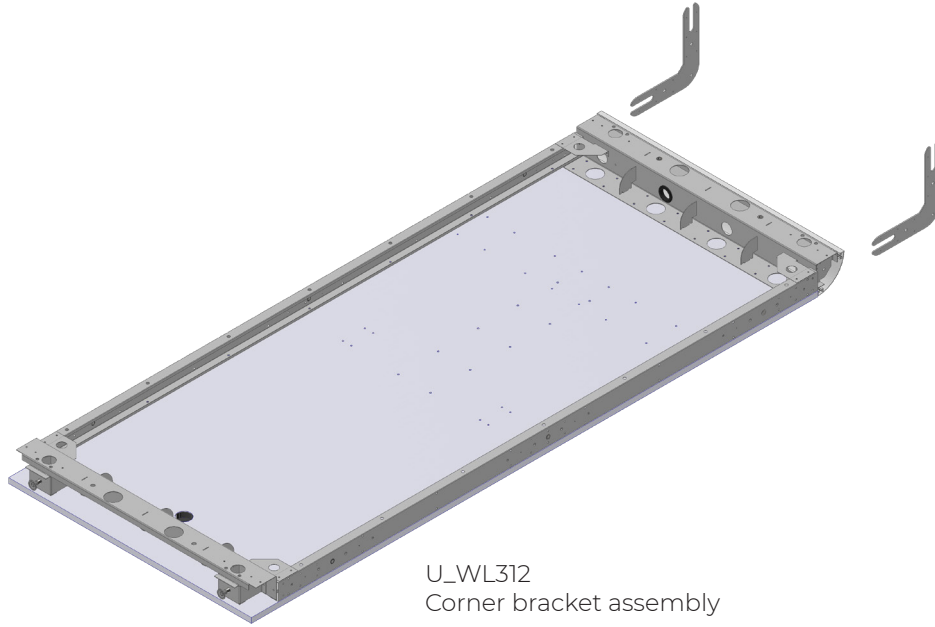

- lay out both wall units on the ground with “rear” side facing up
- slide in corner brackets and secure with FS203 screws on “rear” side only
- attach ceiling unit, ensuring “rear” side is facing up
- secure ceiling to wall using FS208 bolts.

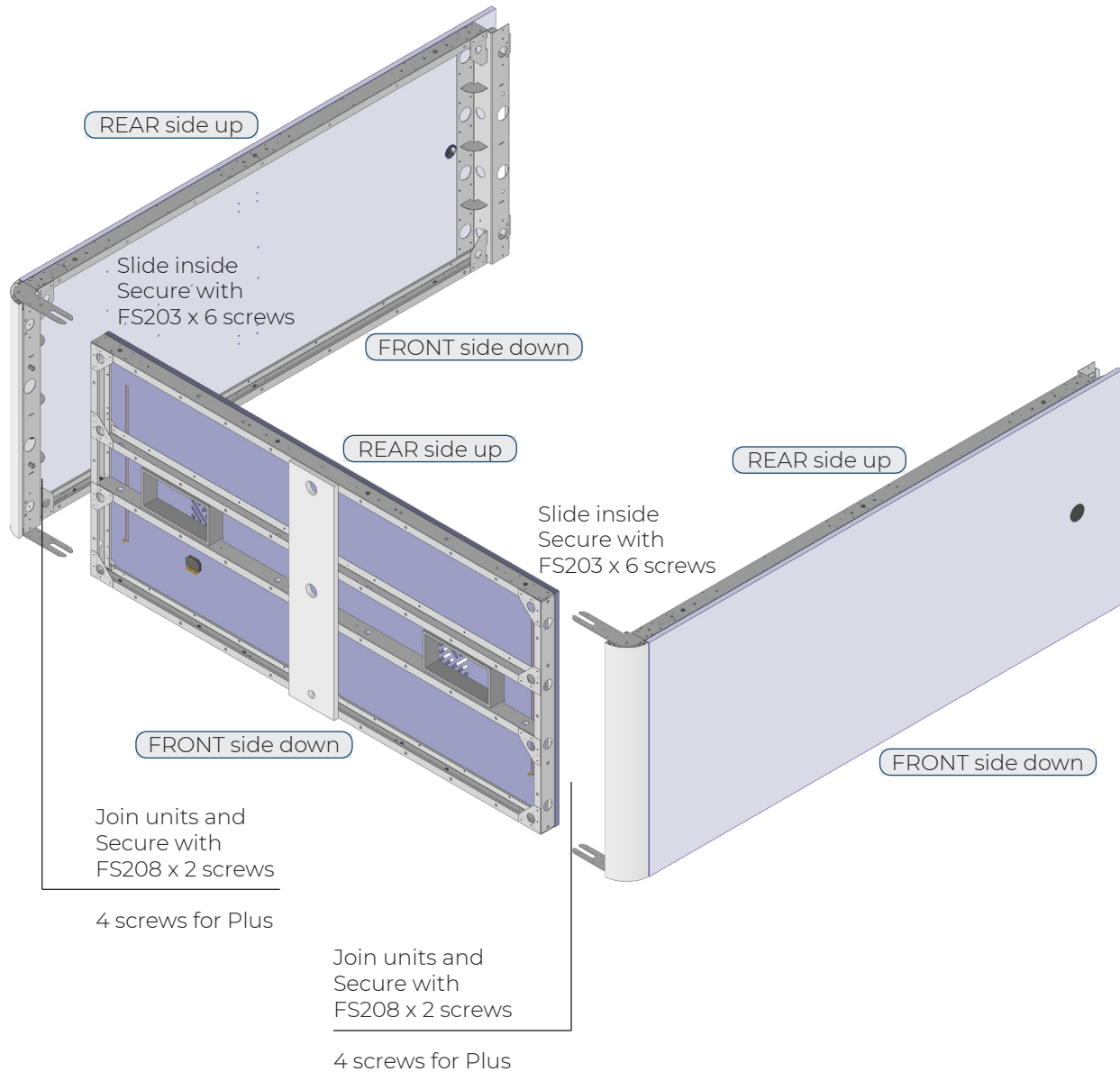

- while still on ground, lay the felt acoustic border on the edges of the unit, secure from inside with FS201 euro screws
- place rubber grommets in all the holes

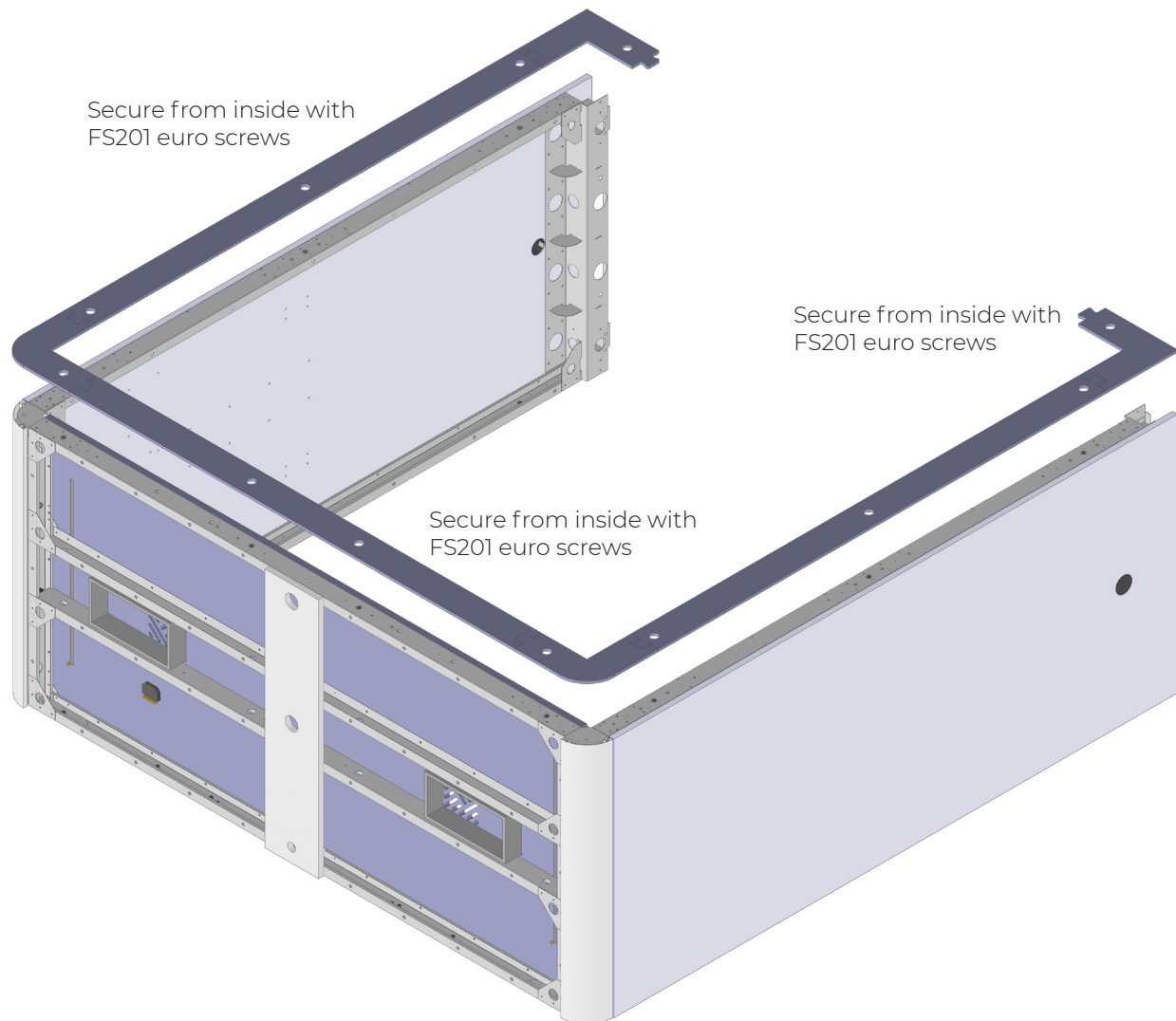

- attach 1 piece of rear glass to the unit and secure using FS213 screws with stand-off cap
- attach butt glass gasket to the edge of glass
- place other rear glass panel on the unit and secure using FS213 screws with stand-off cap

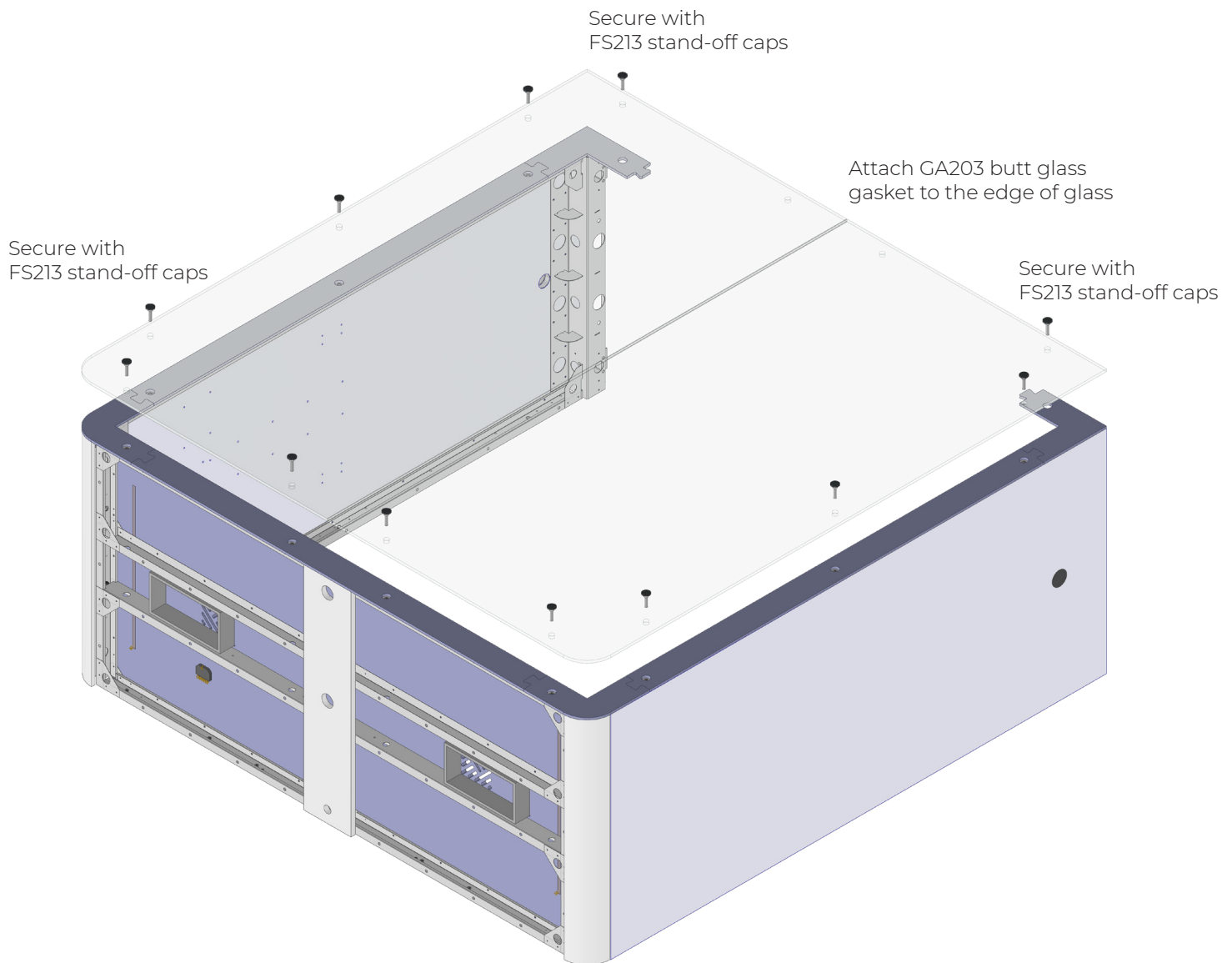

- install rear adjusted skirt and felt acoustic borders to the bottom of the unit with FS218 hex nuts
- adjust the glass and felt acoustic borders as needed, and tighten all FS213 screws with stand off caps
- stand the unit up vertically

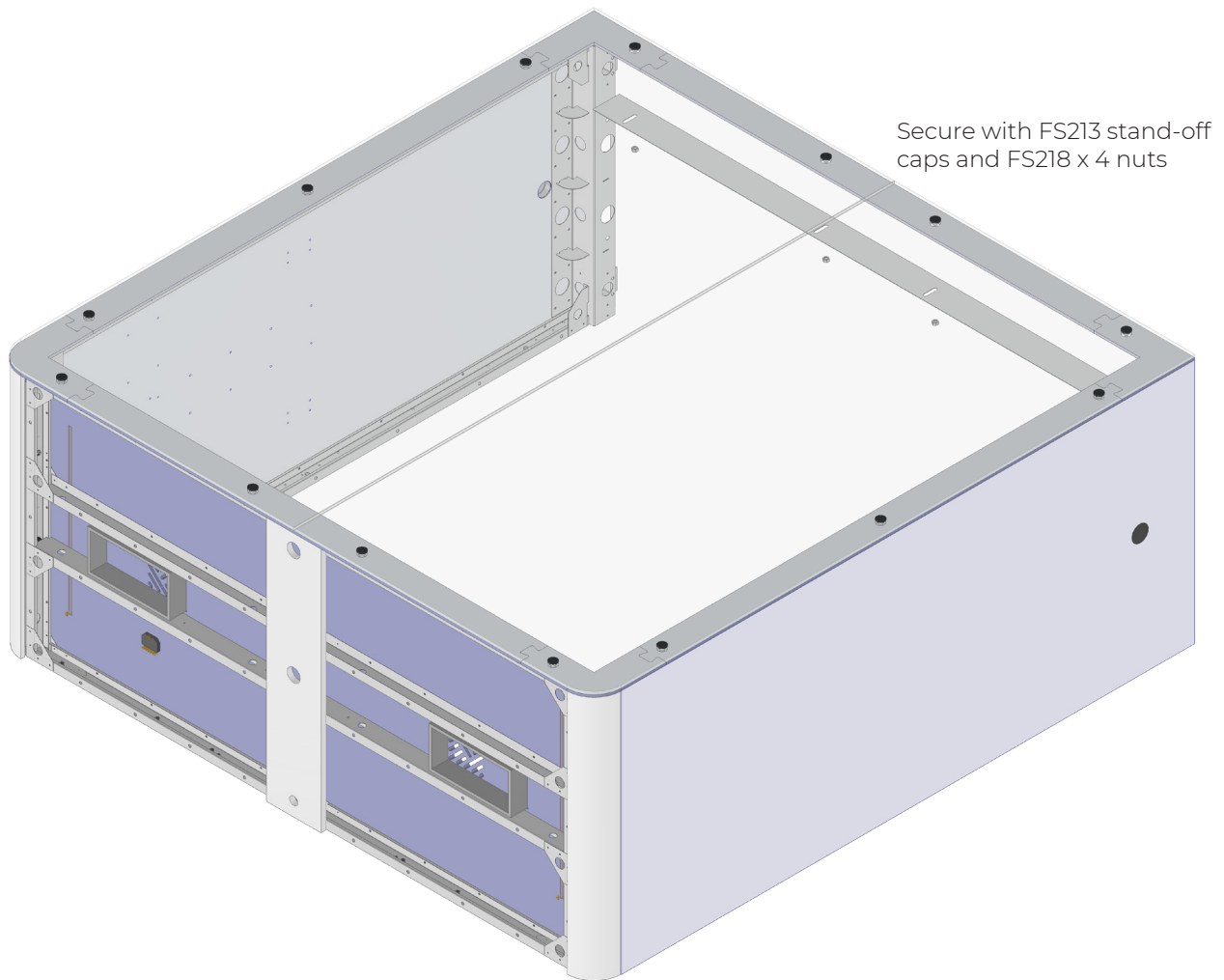

- stand the unit up vertically
- secure corner brackets with FS203 screws on “front” side

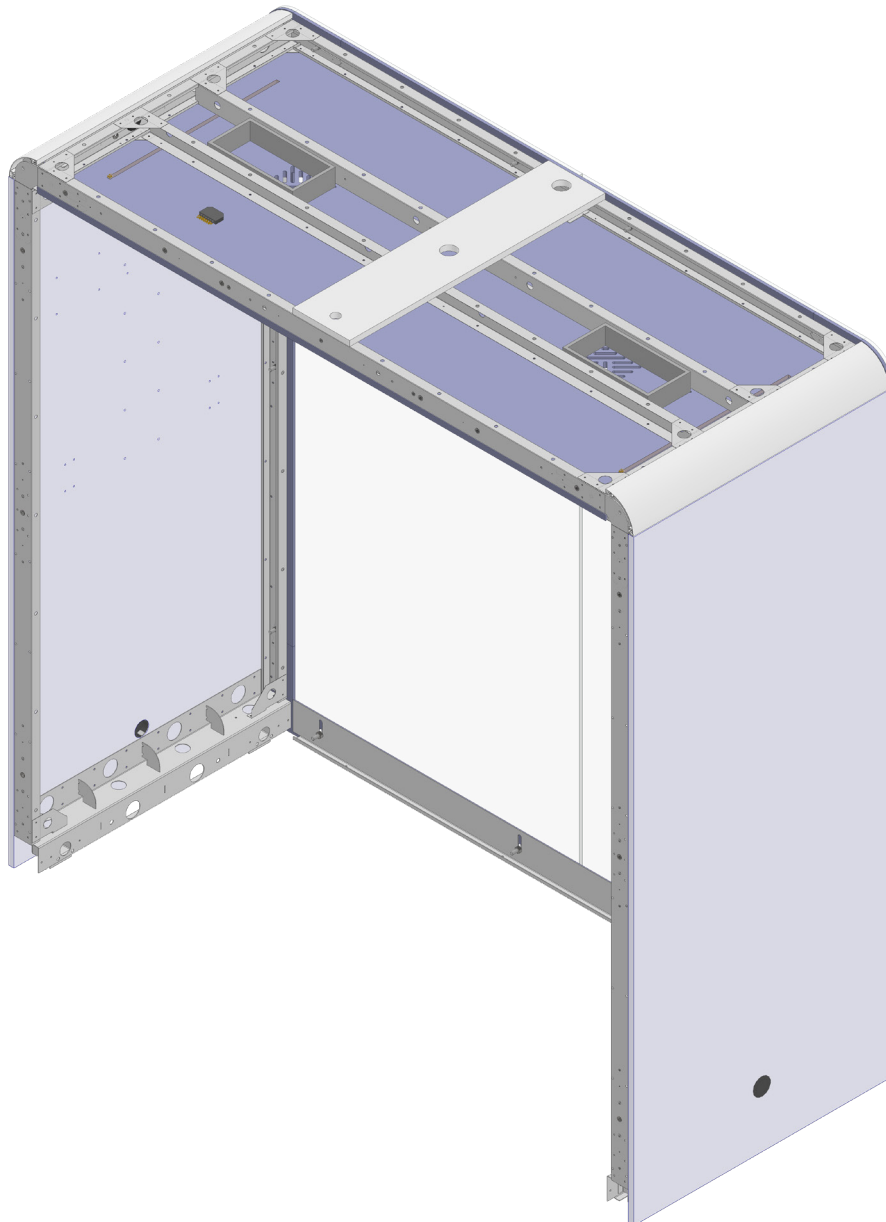

- attach the felt acoustic border on the edges of the unit, secure from inside with FS201 euro screws
- place rubber grommets in all the holes

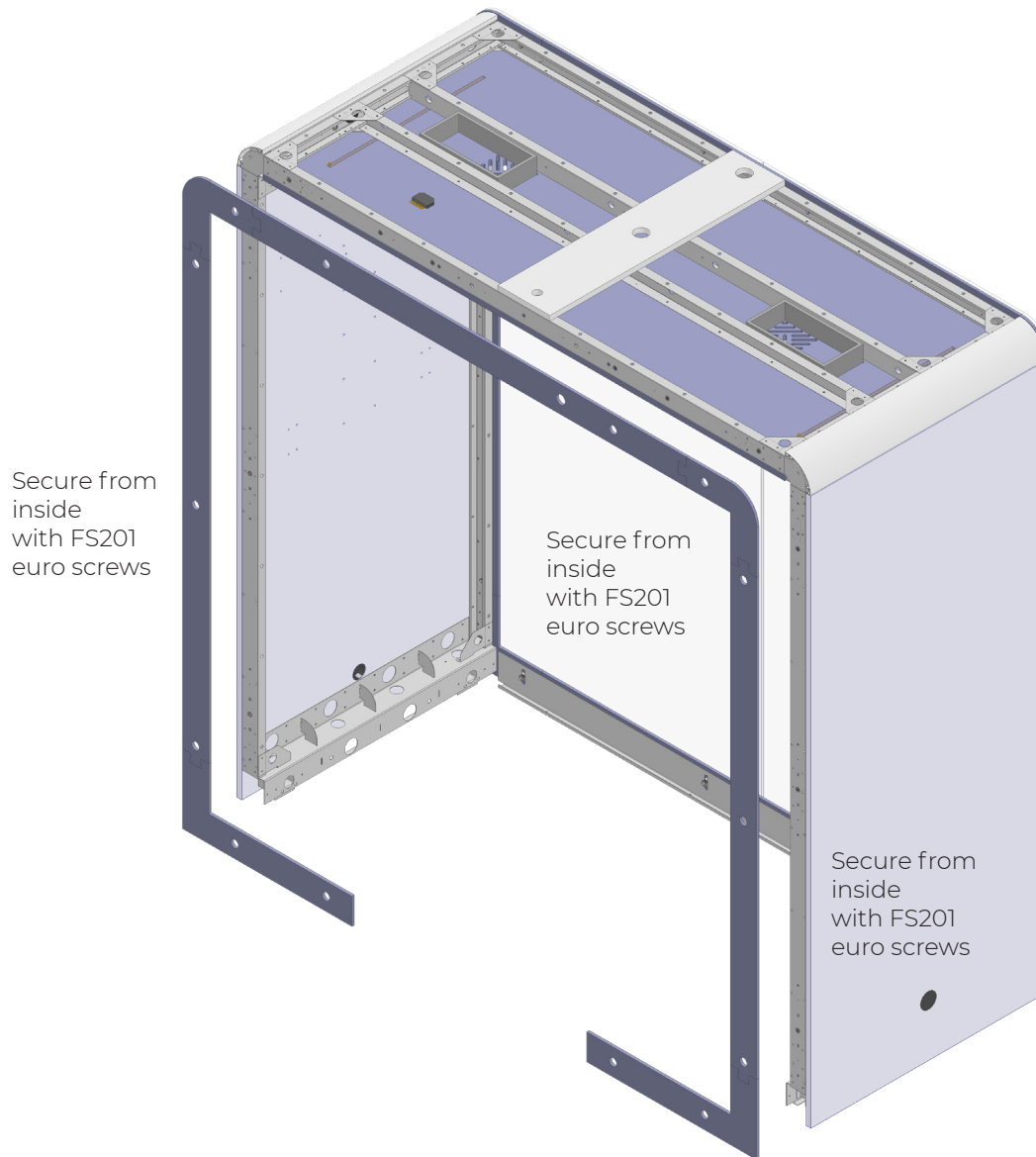

- attach 1 piece of front sidelight glass to the unit and secure using FS213 screws with stand-off cap
- place other front sidelight glass panel on the unit and secure using FS213 screws with stand-off cap

NOTE - DOOR SWING DIRECTION:

When installing the front glass, take note of the hinge hole placement in the 2 front glass segments. Install the glass segments accordingly to determine proper door swing direction.

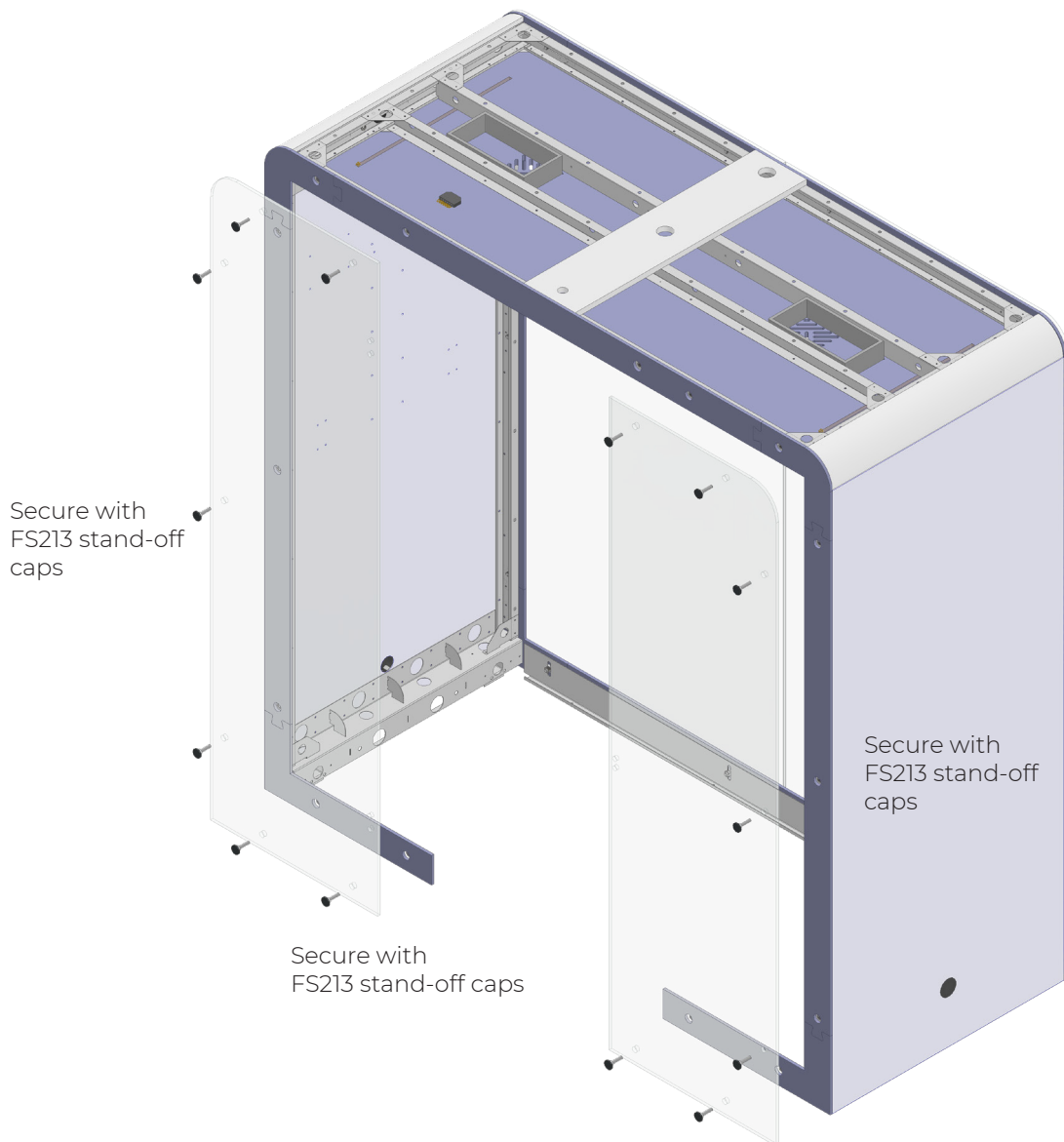

- attach the rest ST341 x 2 adjusted “skirts”
- start to level the unit using the leveler bolts
- ensure that the booth is plumb vertically
- secure adjusted “skirts” on sides with black self tapping screws
- then anchor the adjusted “skirts” to the floor with dowels and screws

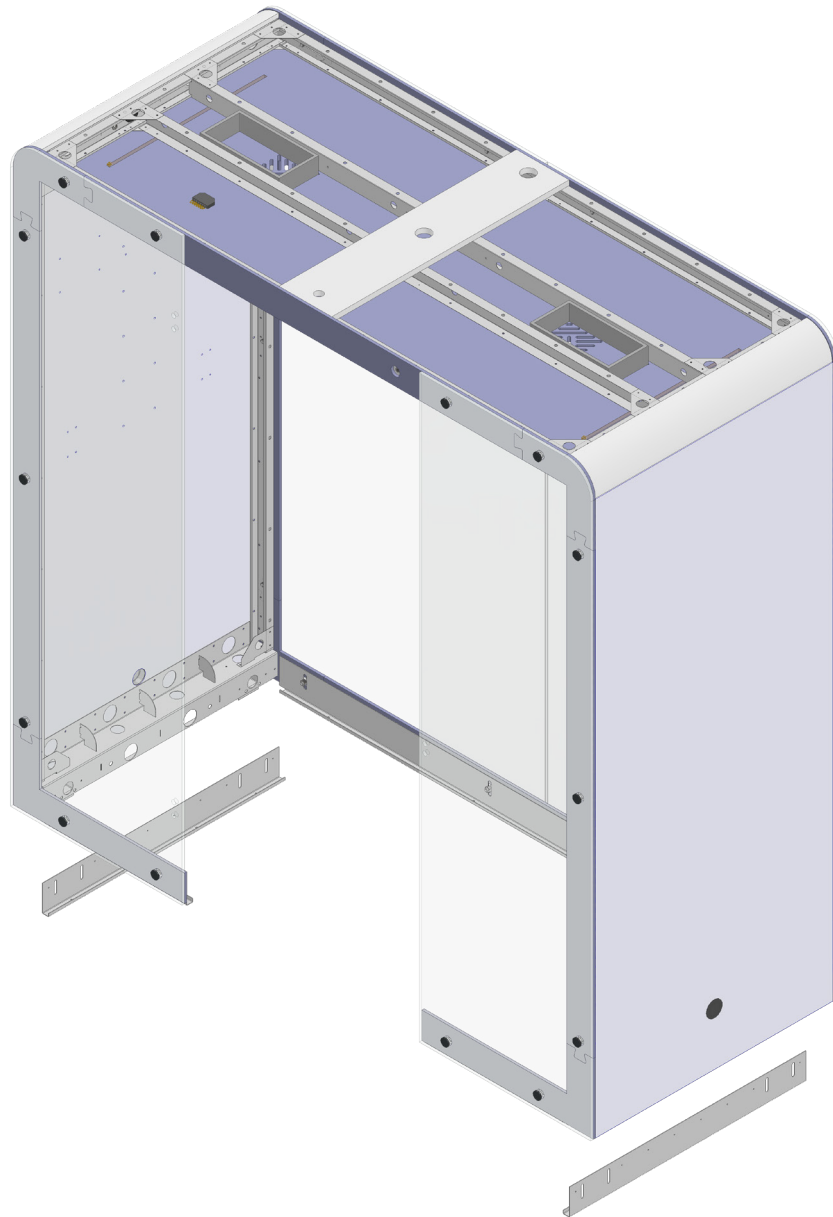

- attach all decorative boards to face of adjusted “skirts”
- secure with FS220 self tapping screws
- plug FS219 plastic cups to conceal the M10 nuts
- trim the BB313 to size to conceal floor anchored bolts

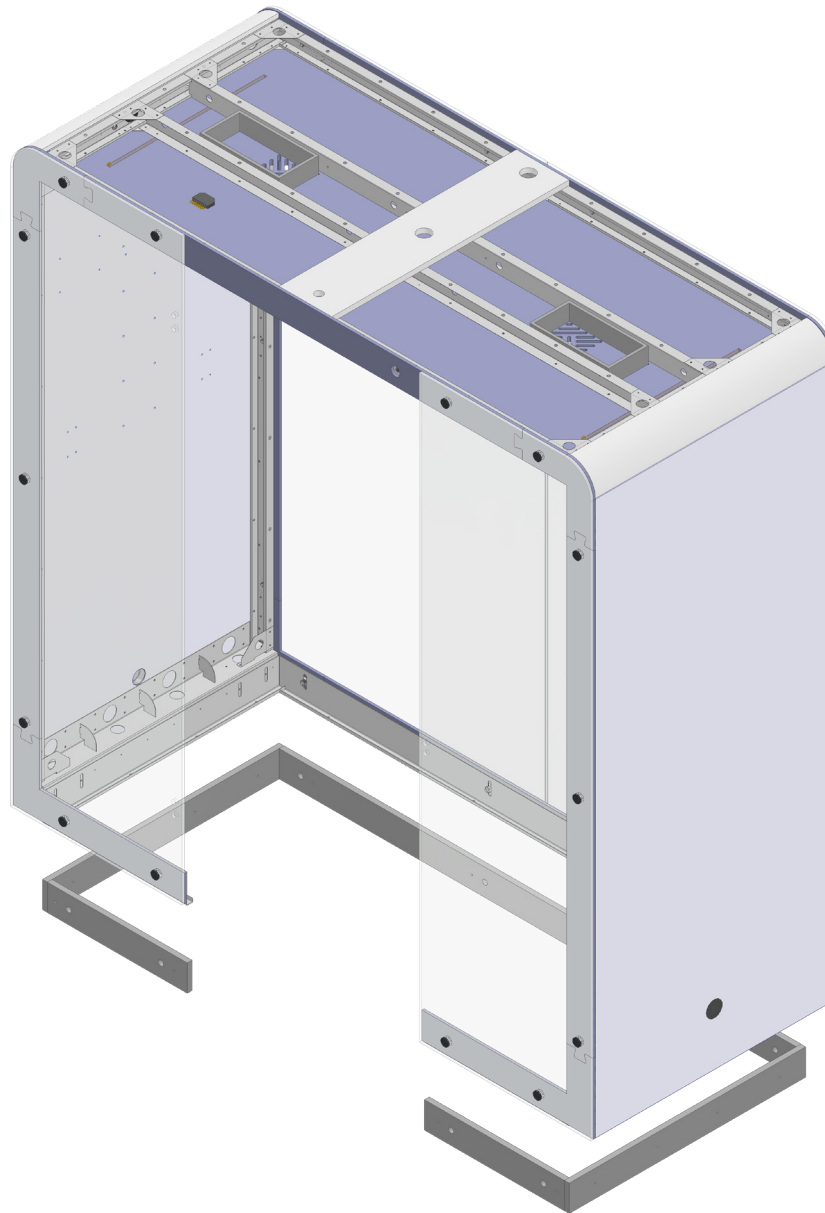

- run output wires through the ceiling
- connect wires to the splitter at the ceiling
- connect lights and speakers (optional) to the splitter
- run input cable inside the wall down through plastic cap out
- put the roof panels on top and connect all fans to the splitter

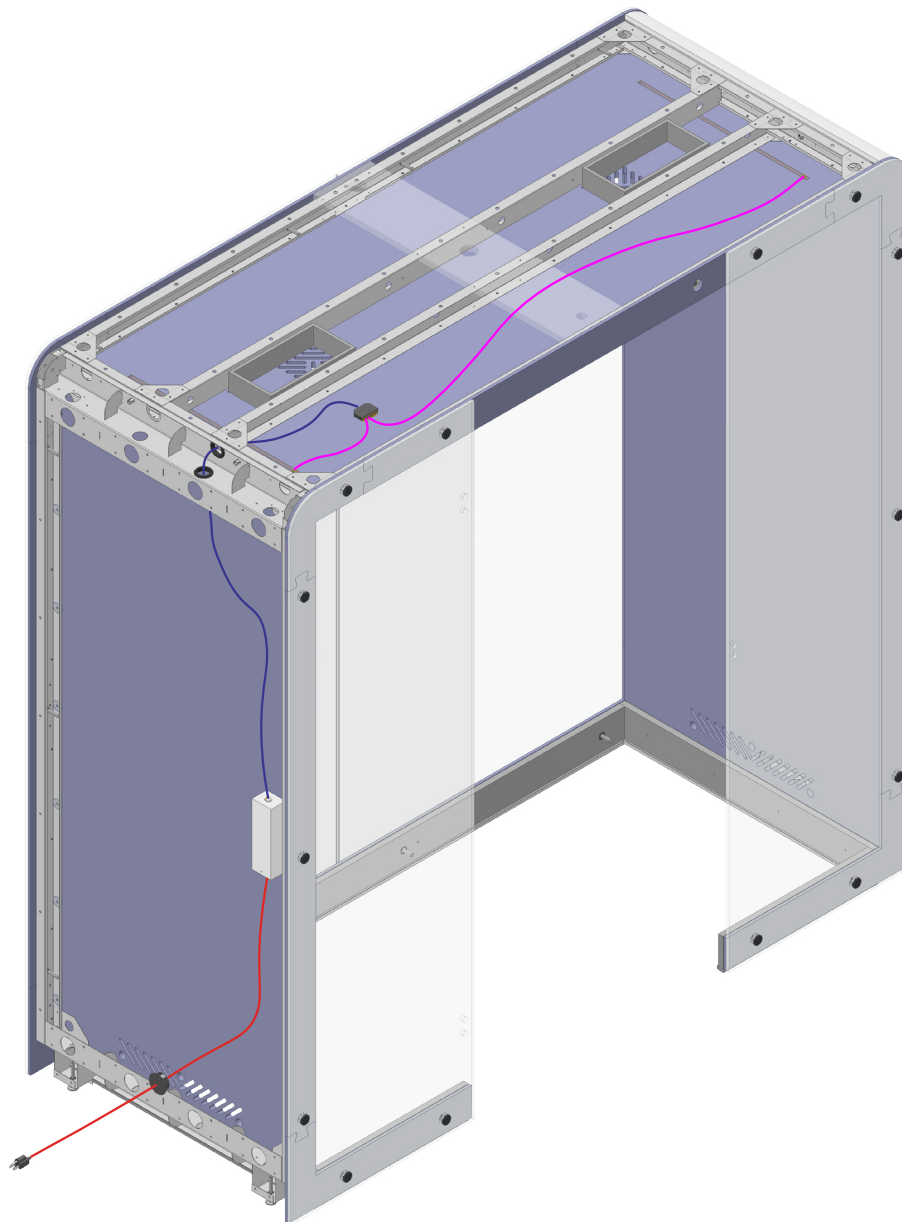

Once your side glass is installed you are able to mount your door. Be sure to install the silicon sleeves on every screw that goes through the glass unit.

Step 1: Get one hinge and one back plate with silicon sleeve and rubber spacer. Place the back plate to the inside of the unit where the pre drilled hole is located in glass and place the hinge on the exterior side of the same holes. Use screws provided in the hinge box to fasten the two pieces together. Do not over tighten at this point, leave it so you have some room to adjust the door. Do the same to install the second hinge.

Step 2: Bring the door up to both hinges and repeat steps to mount the door glass to the hinge. Snug the door to the hinges while supporting the door. Have one person inside the unit and one person on the exterior of the unit. Gently close the door making sure not to chip or mar the glass. Check for alignment and level while still supporting the door and once satisfied have the person on the interior tighten the screw M6 .

Step 3: Install cover plate on the interior to the glass backer plate use the Allan key provided in the hinge box to install this plate.

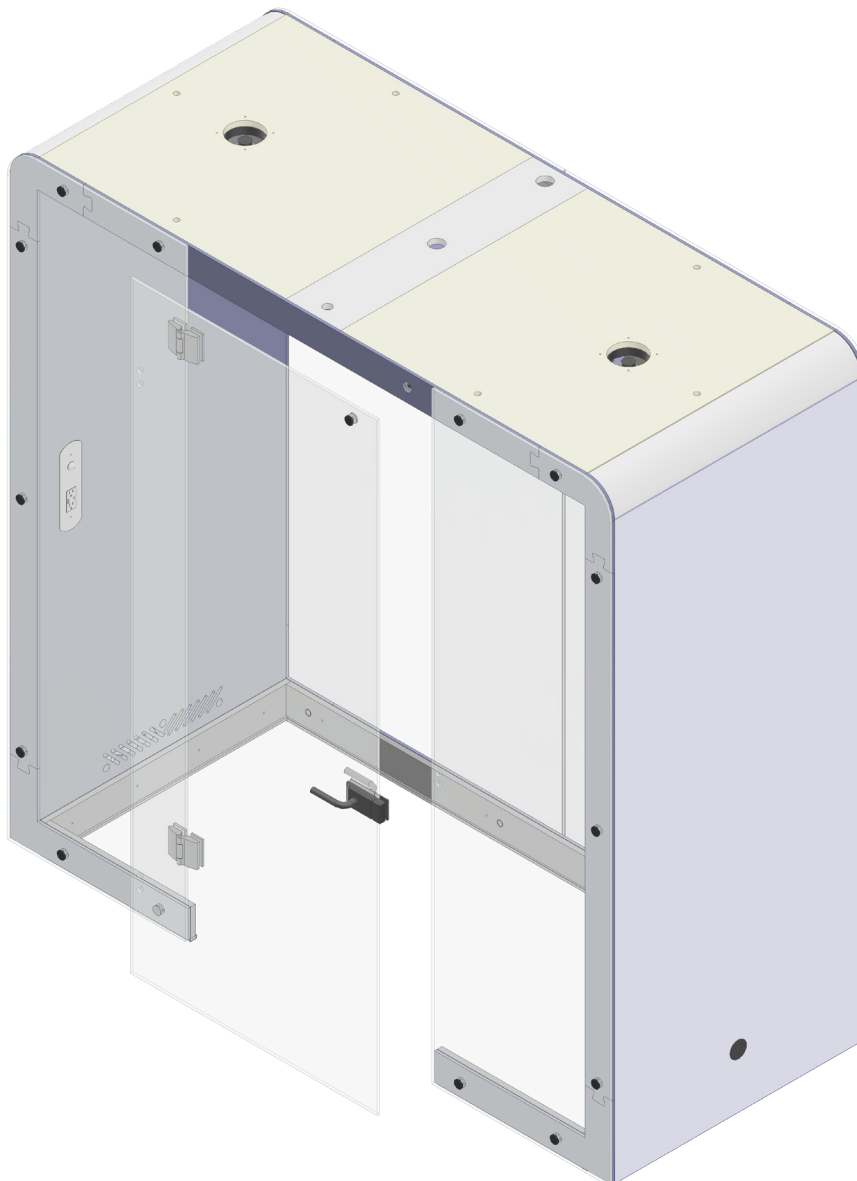

- clean the product

