

# **Kubebooth Kteam**

## **BACK UNIT ASSEMBLY GUIDE**



FS201 x16 - Self tapping screw for units corners assembly



FS202 x48 - Self tapping screw for flat frame assembly

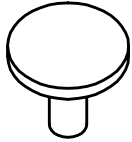

FS203 x28 - Stand-off cap M10 for glass assembly



FS205 x4 - Black M6 screw for flat frame (door side) assembly

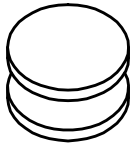

FS206 x2 - Door magnets set

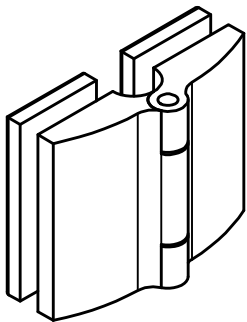

Door hinges x2

Door handle set x1

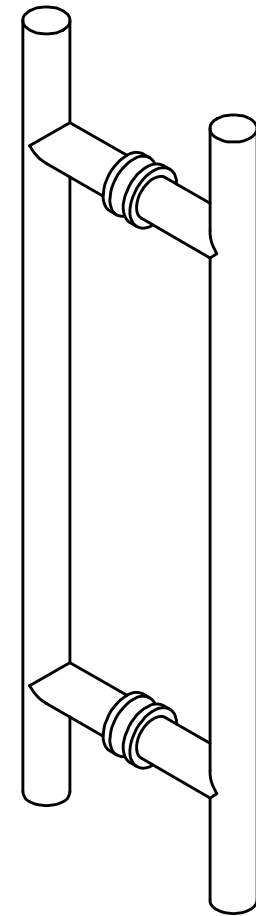

Stand-off cap key

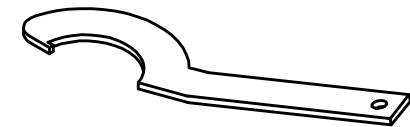

Kteam\_GU\_P01

Outside View

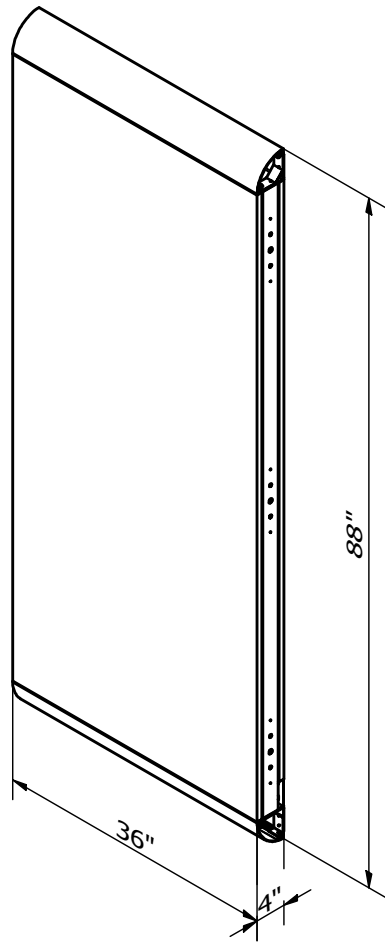

Inside View

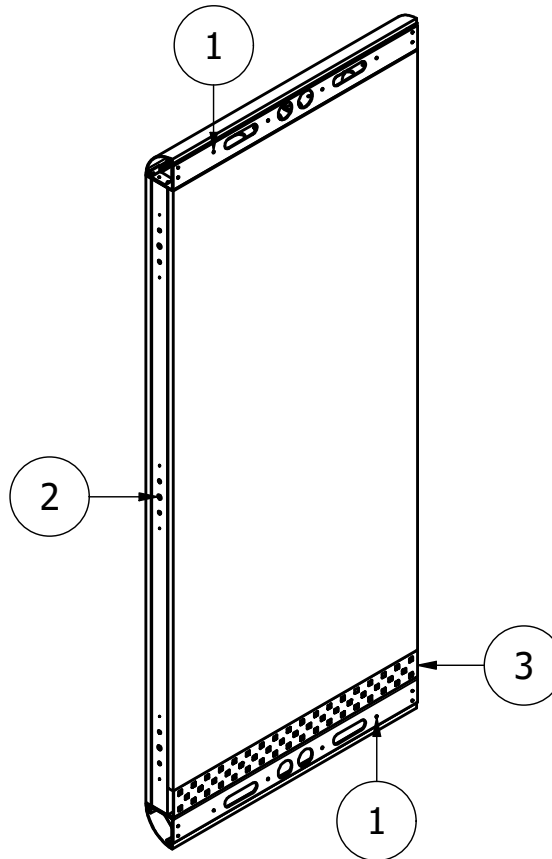

1. Holes for unit corners assembly

2. Holes for metal frame and glass/door assembly

3. Airflow grill

Configuration <b>Kteam</b>	PACKAGE	WALL UNIT (prefabricated)	Stage ■	Page 02
-------------------------------	---------	---------------------------	------------	------------

Unit View

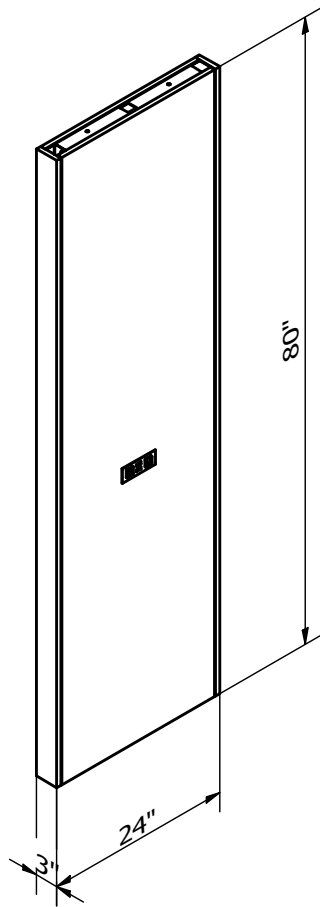

Removed panel View

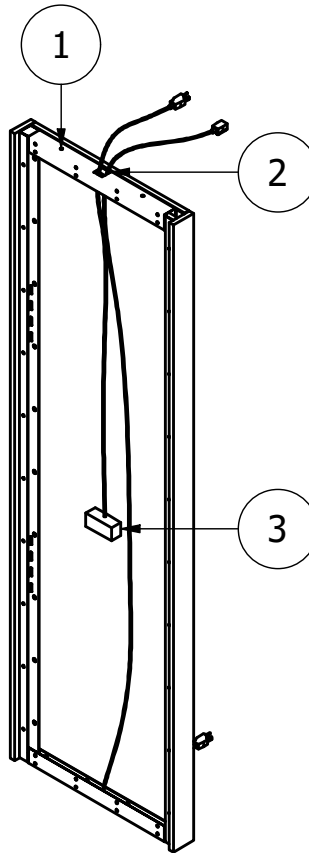

1. Holes for assembly
2. Cutouts for wiring
3. Power/Data outlet

Top w/Brackets to be installed upon assembling completion

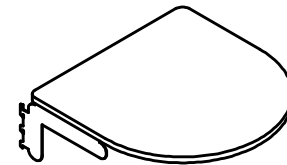

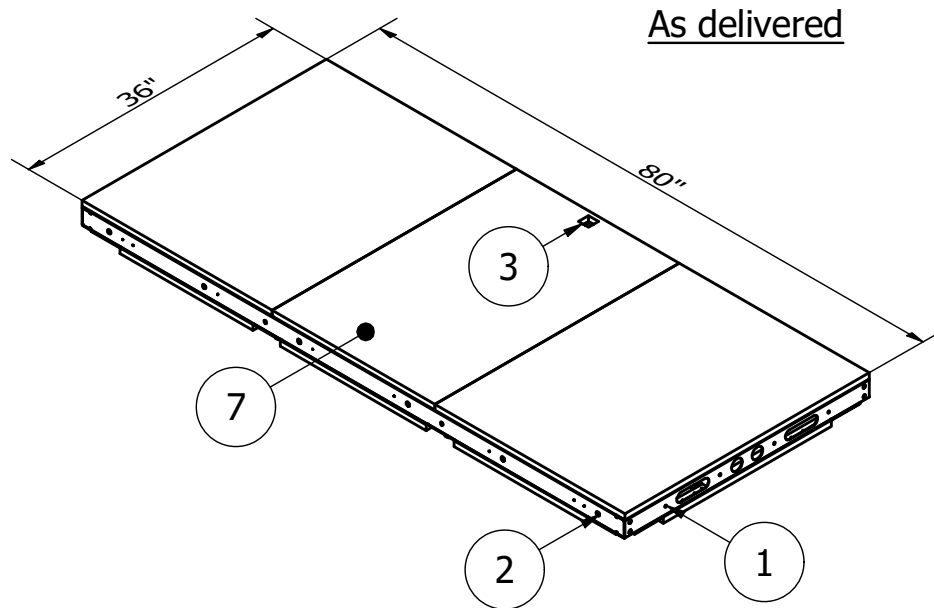

1. Holes for unit corners assembly
2. Holes for metal frame and glass/door assembly
3. Cutouts for wiring (for BACK unit only)
4. Casters w/Leveler
5. Leveler bolt
6. Cutouts for seismic bracket
7. Floor access panel

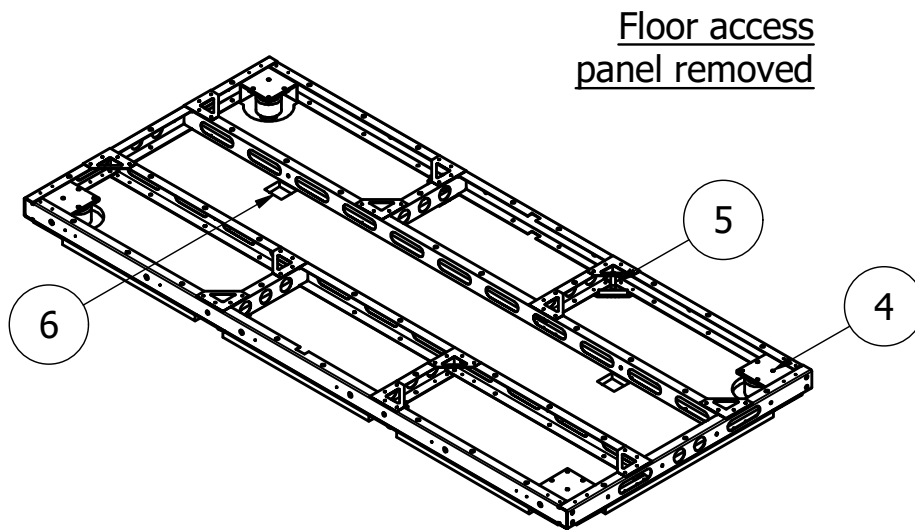

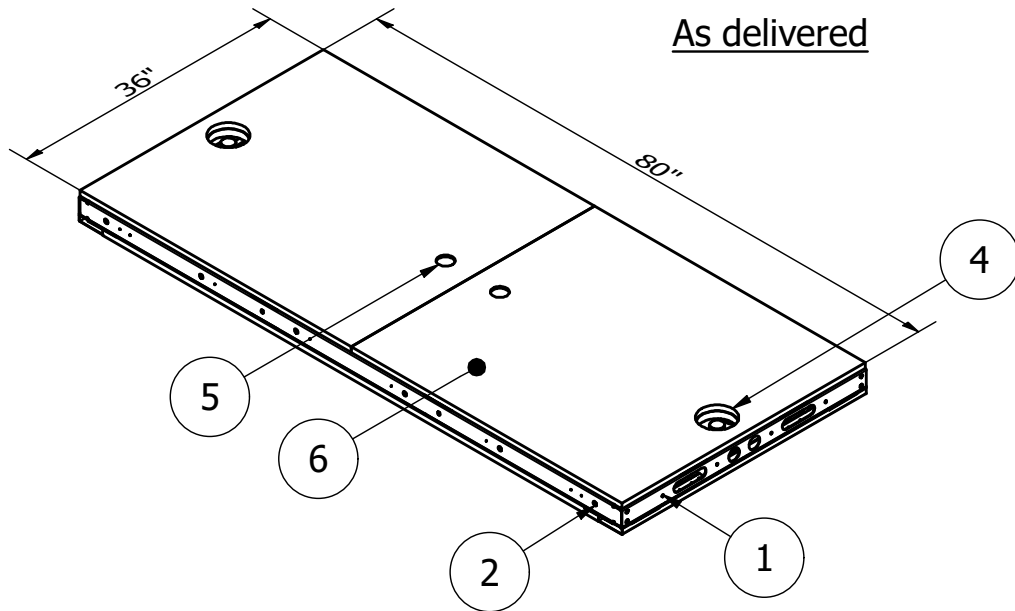

1. Holes for unit corners assembly

2. Holes for metal frame and glass/door assembly

3. Cutouts for wiring (for BACK unit only)

4. Cutouts for fans

5. Knock out hole for sprinkler (optional)

6. Roof access panel

Roof access panel removed

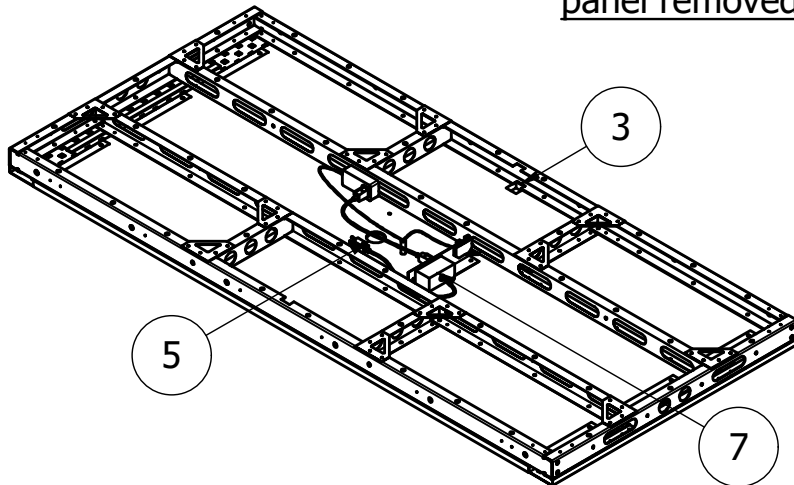

7. Power control system inc. (power box w/outlets, LED driver, 2 LED lights, motion sensor, splitter box, 2 air fans)

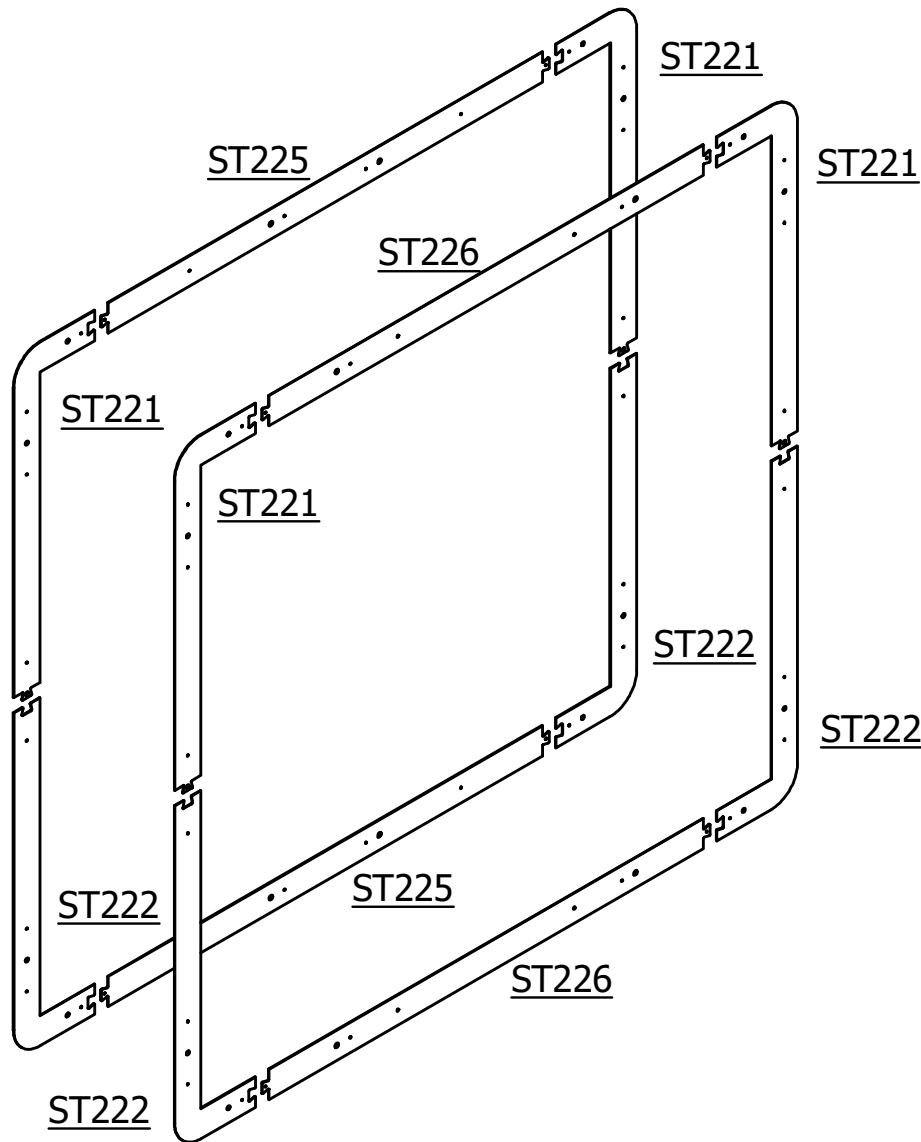

ST221 - Frame metal part (2 on front, 2 on back) with self tapping screws (FS201 x 8) per piece. This part has 5 holes for glass assembly.

ST225 - Frame metal part on the rear of the unit with Self tapping screws (FS201 x 6). This part has 2 holes for glass assembly.

ST226 - Frame metal part on the front of the unit with self-tapping screws (F201 x 4) for glass assembly and 2 for M6 Screws (F205)

All parts have plastic gaskets on the edges

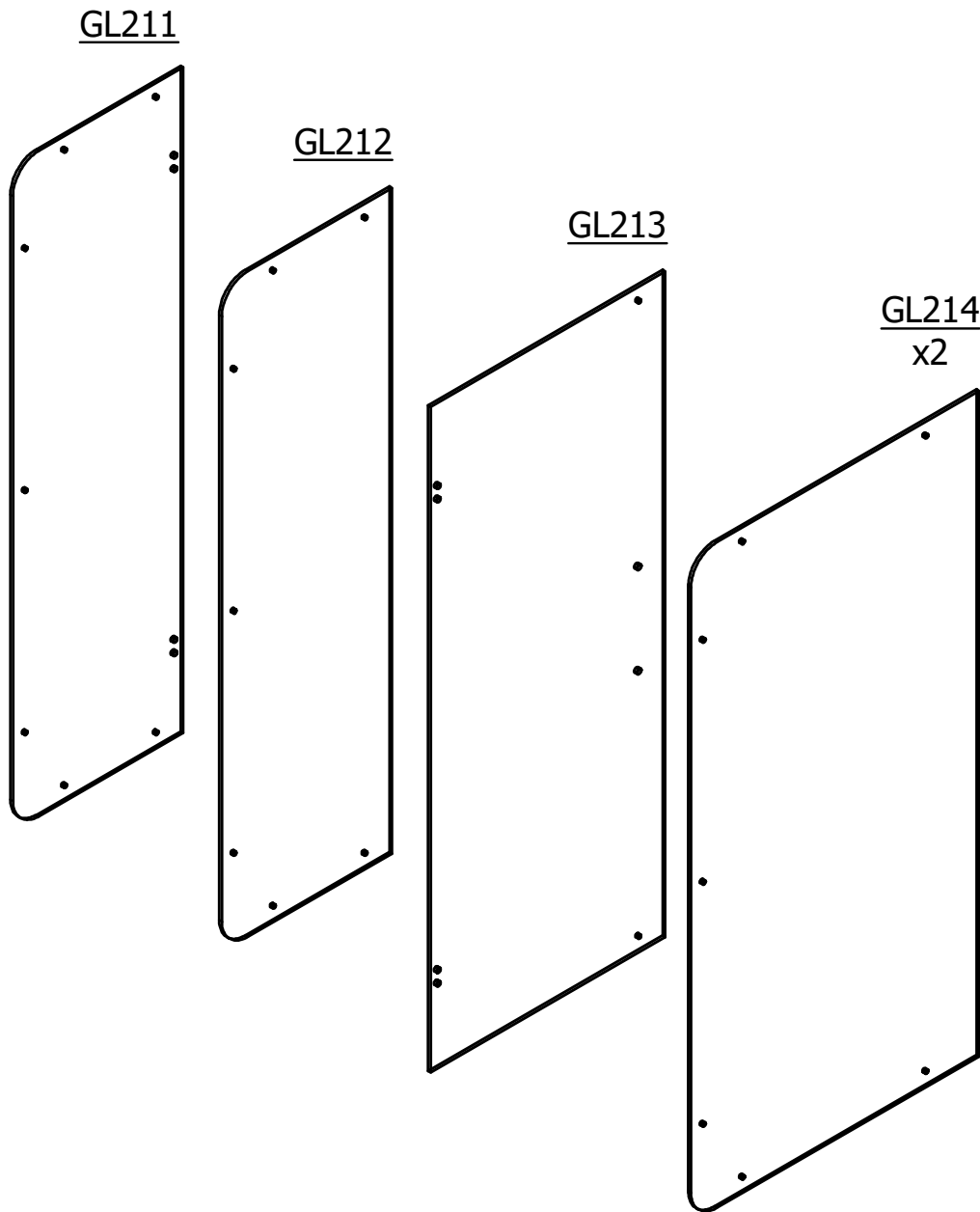

GL211 - Sidelight glass panel has 7 holes for assembly by M10 countersunk screw FS203 with plastic socket cap FS204 two pairs of holes for door hinges assembly

GL212 - Sidelight glass panel has 7 holes for assembly by M10 countersunk screw FS203 with plastic socket cap FS204

GL213 - Door glass panel has two pairs of holes for door hinges assembly  
 pair of holes for handle  
 pair of holes for magnets

GL214 - Back glass panel x2 has 7 holes for assembly by M10 countersunk screw FS203 with plastic socket cap FS204



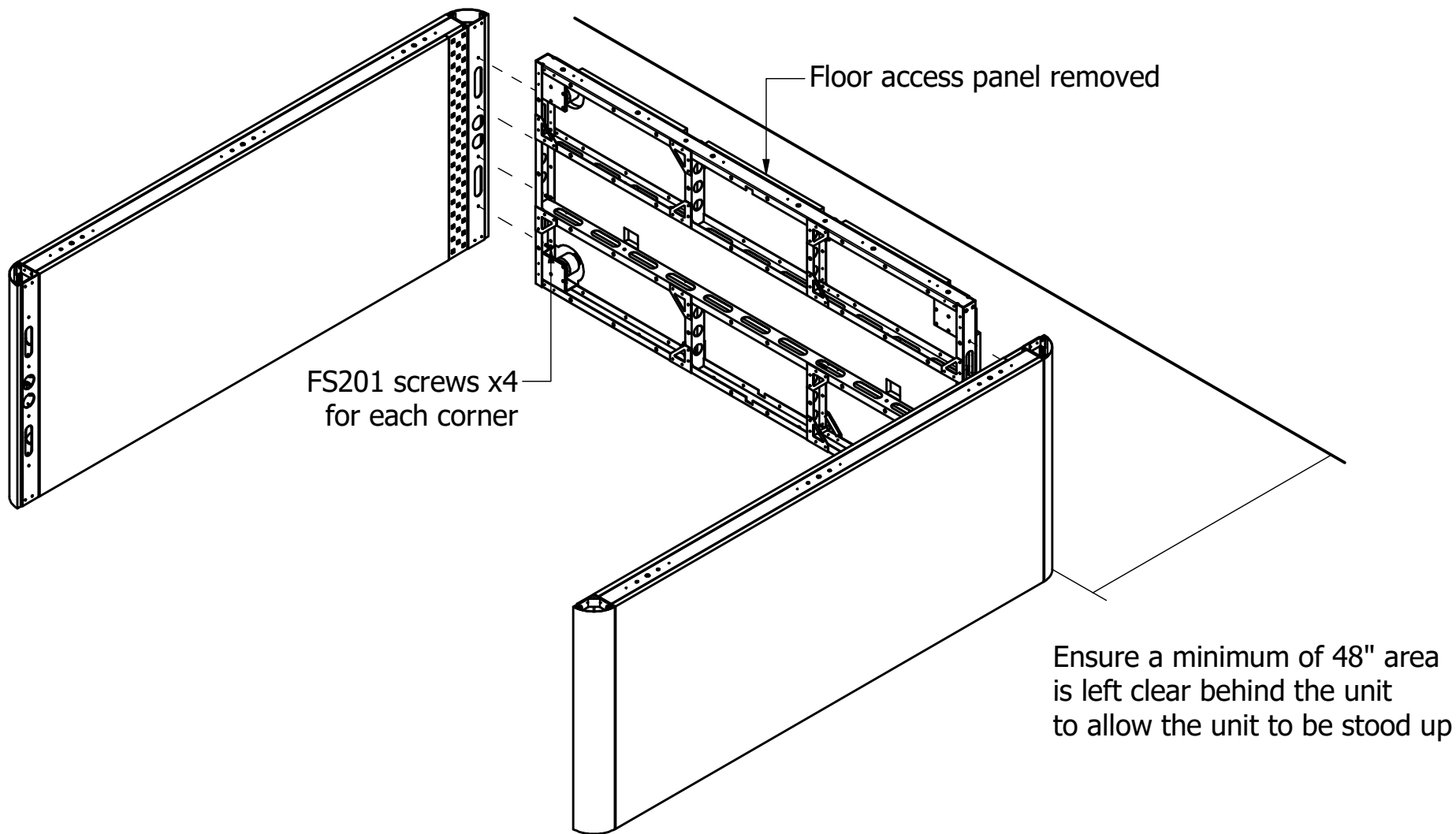

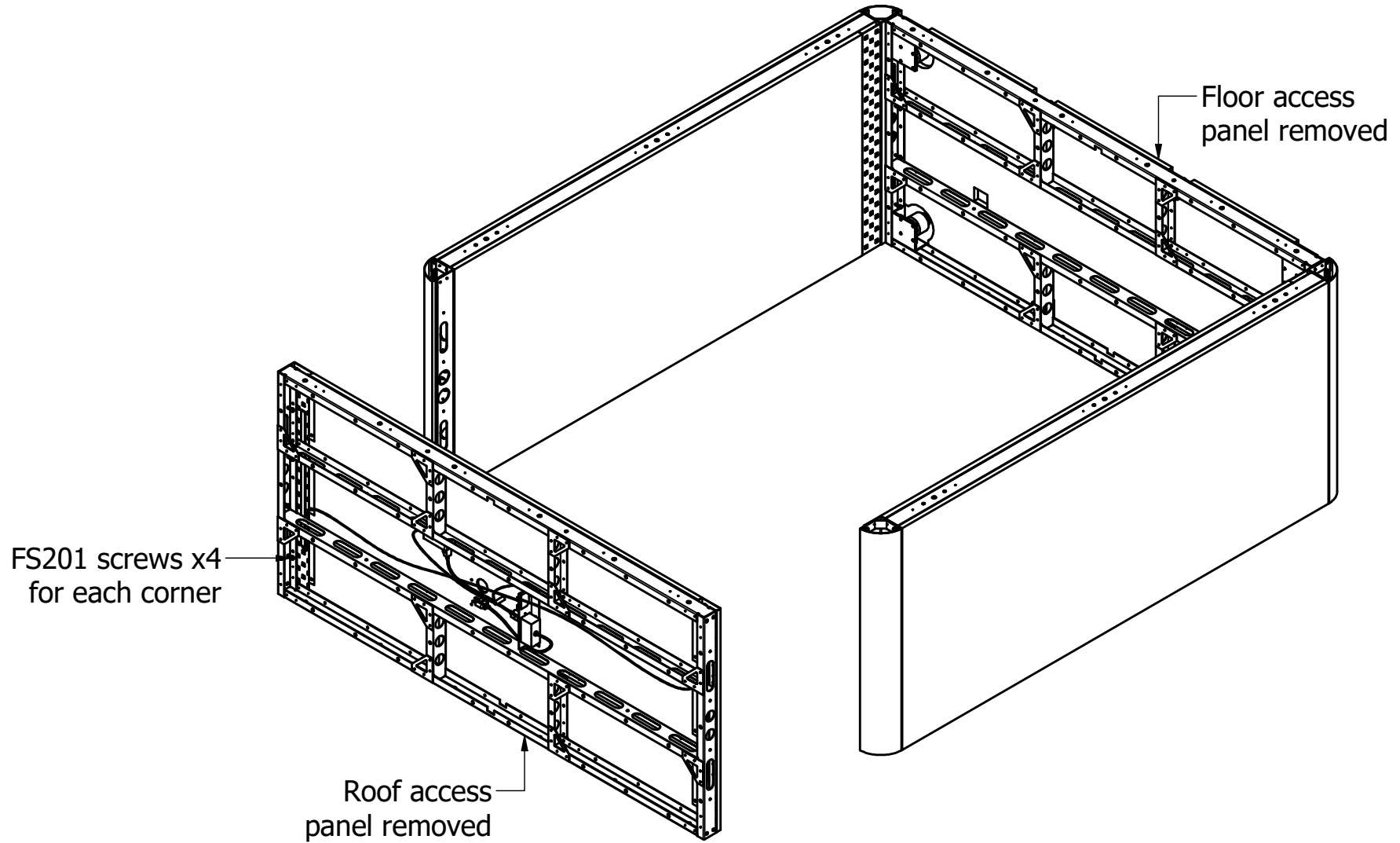

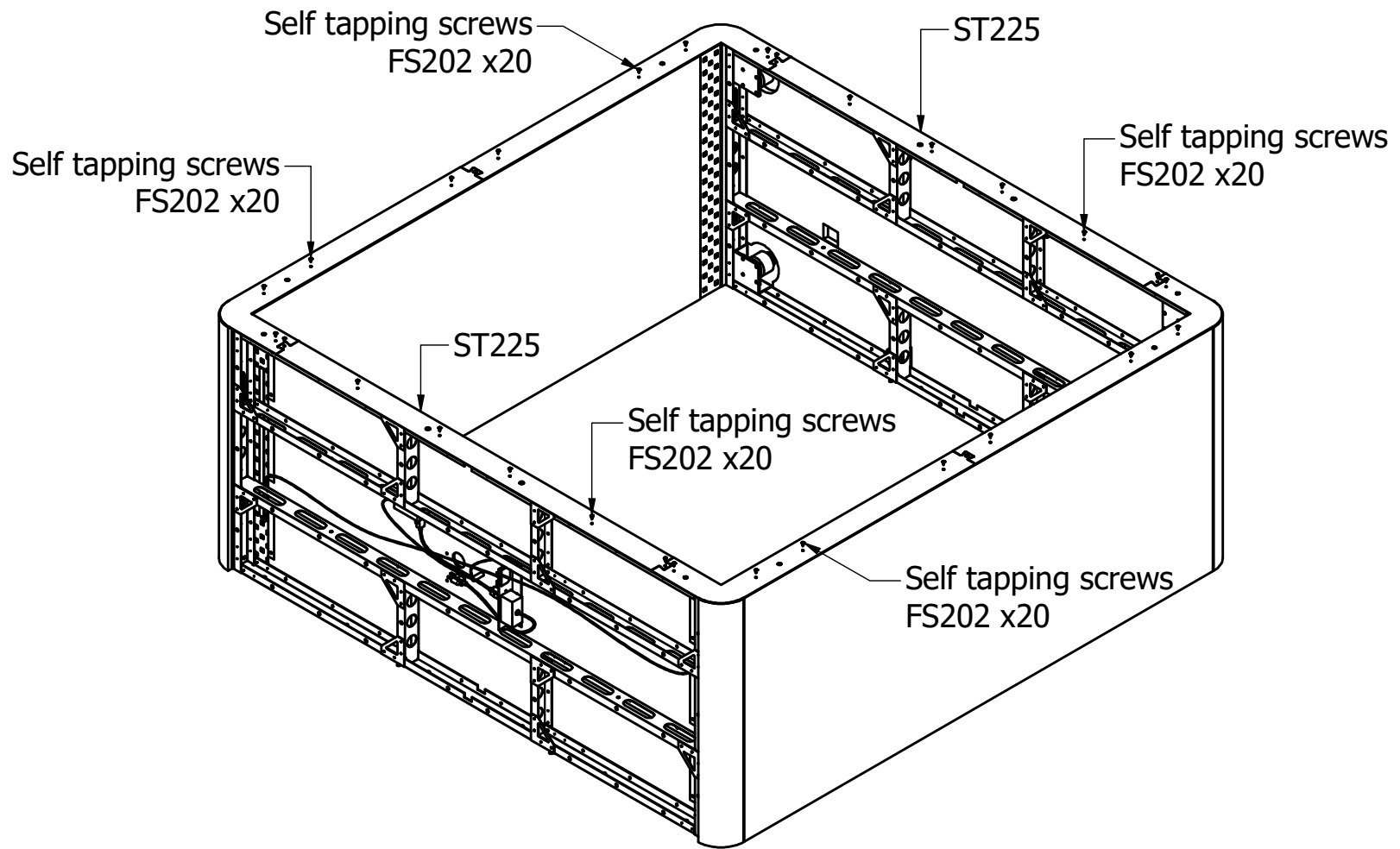

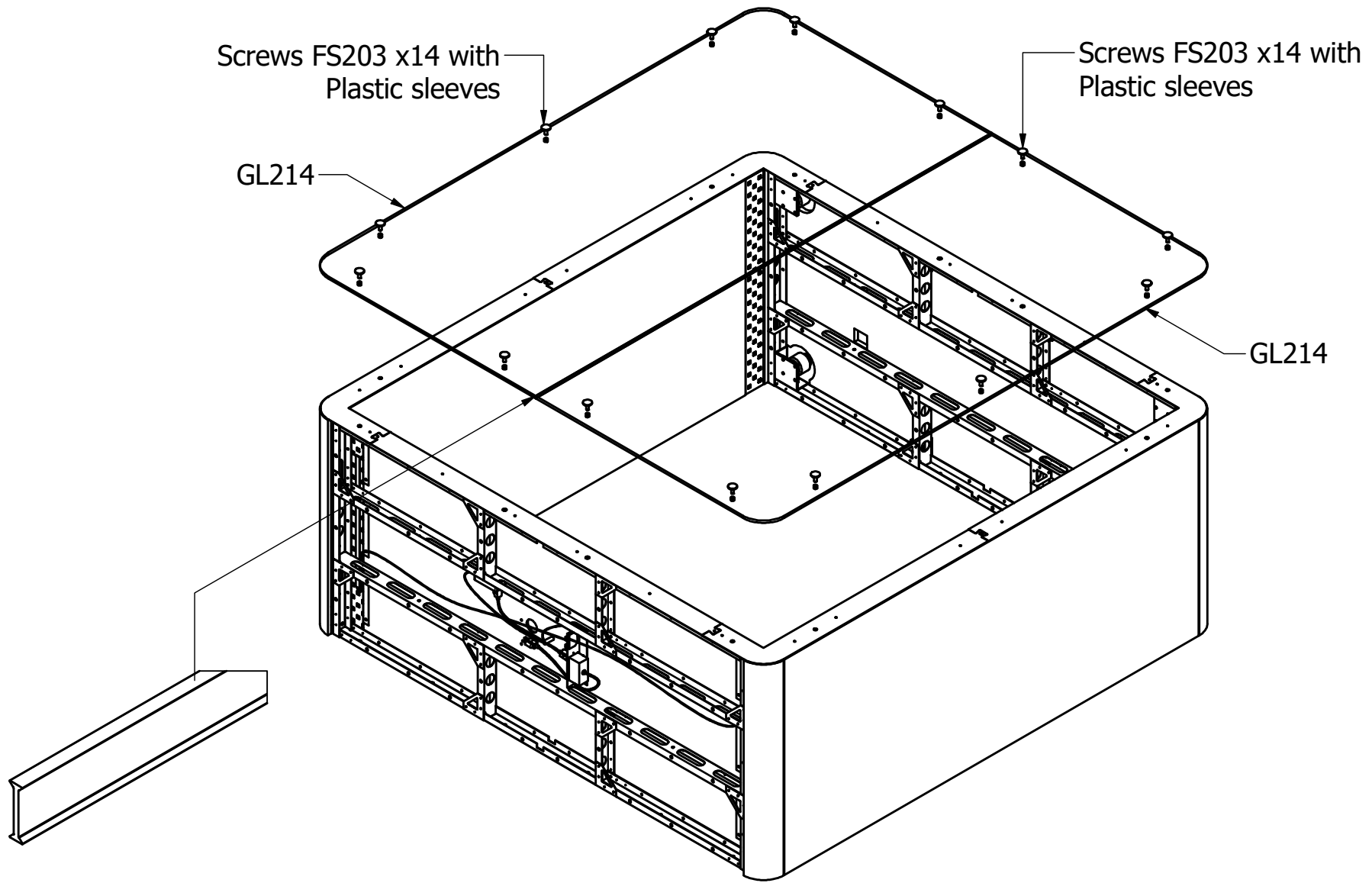

Insert Acrylic seal between glass. Be sure to remove plastic to expose glazing tape, this ensures a good bond.

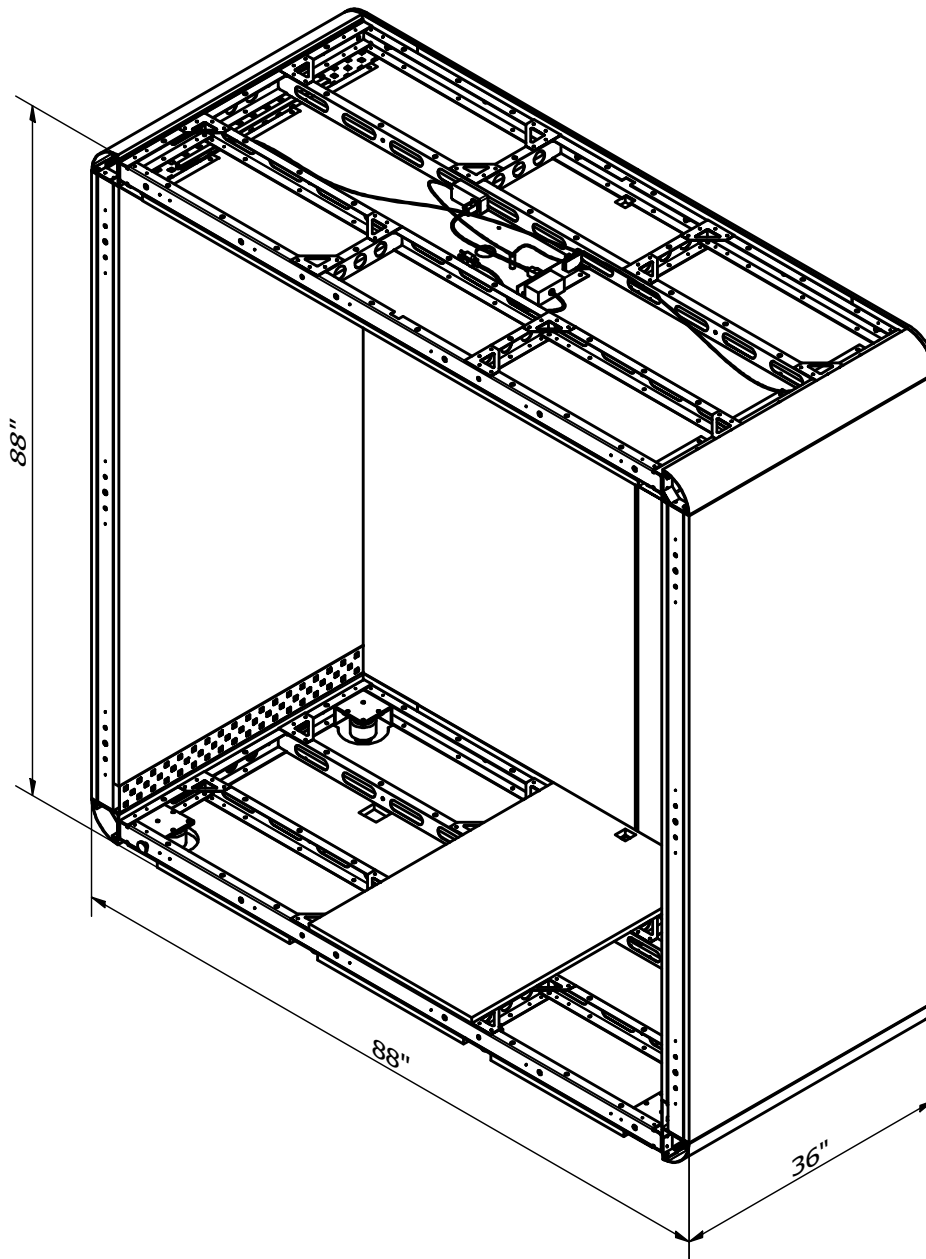

Ensure levelers have been retracted so that wheels are exposed. This will allow the unit to be rolled into its final installation location. Then level the unit.

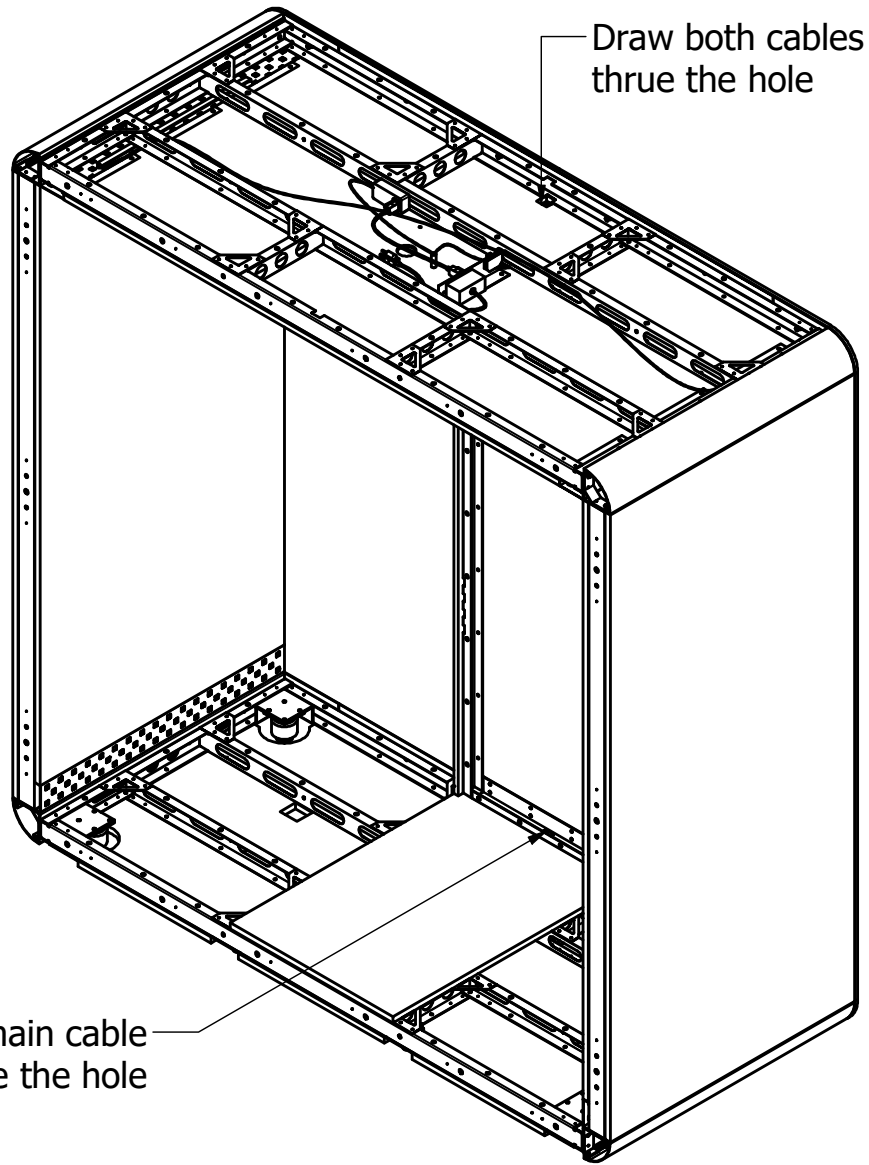

Remove front panel (with electrical) of console unit. Bring inside to the glass and align with floor panel edges. Screw to the floor/ceiling panels.

Console unit skin panel removed

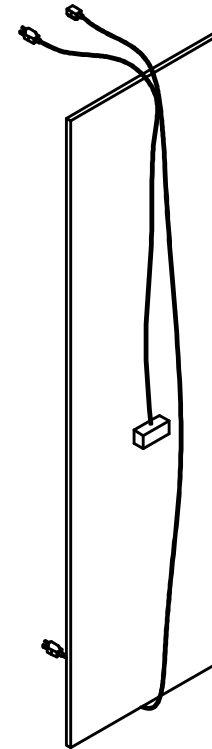

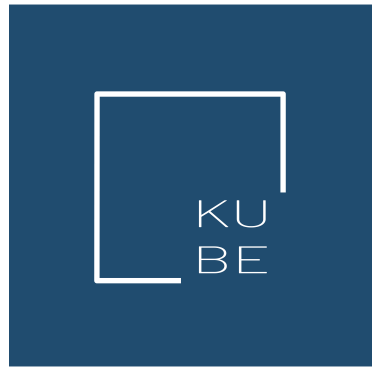

# **Kubebooth Kteam**

## **FRONT UNIT ASSEMBLY GUIDE**

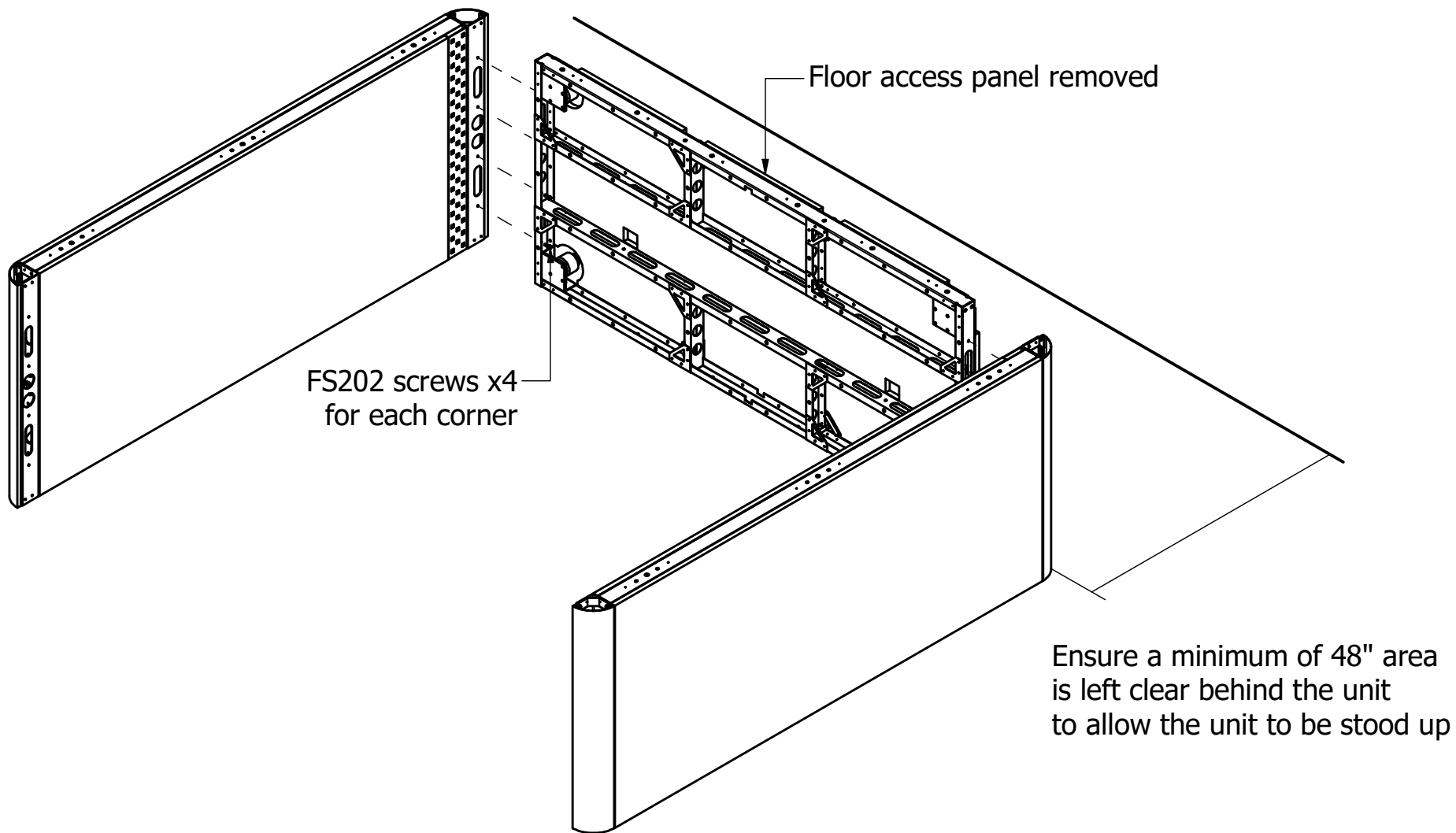



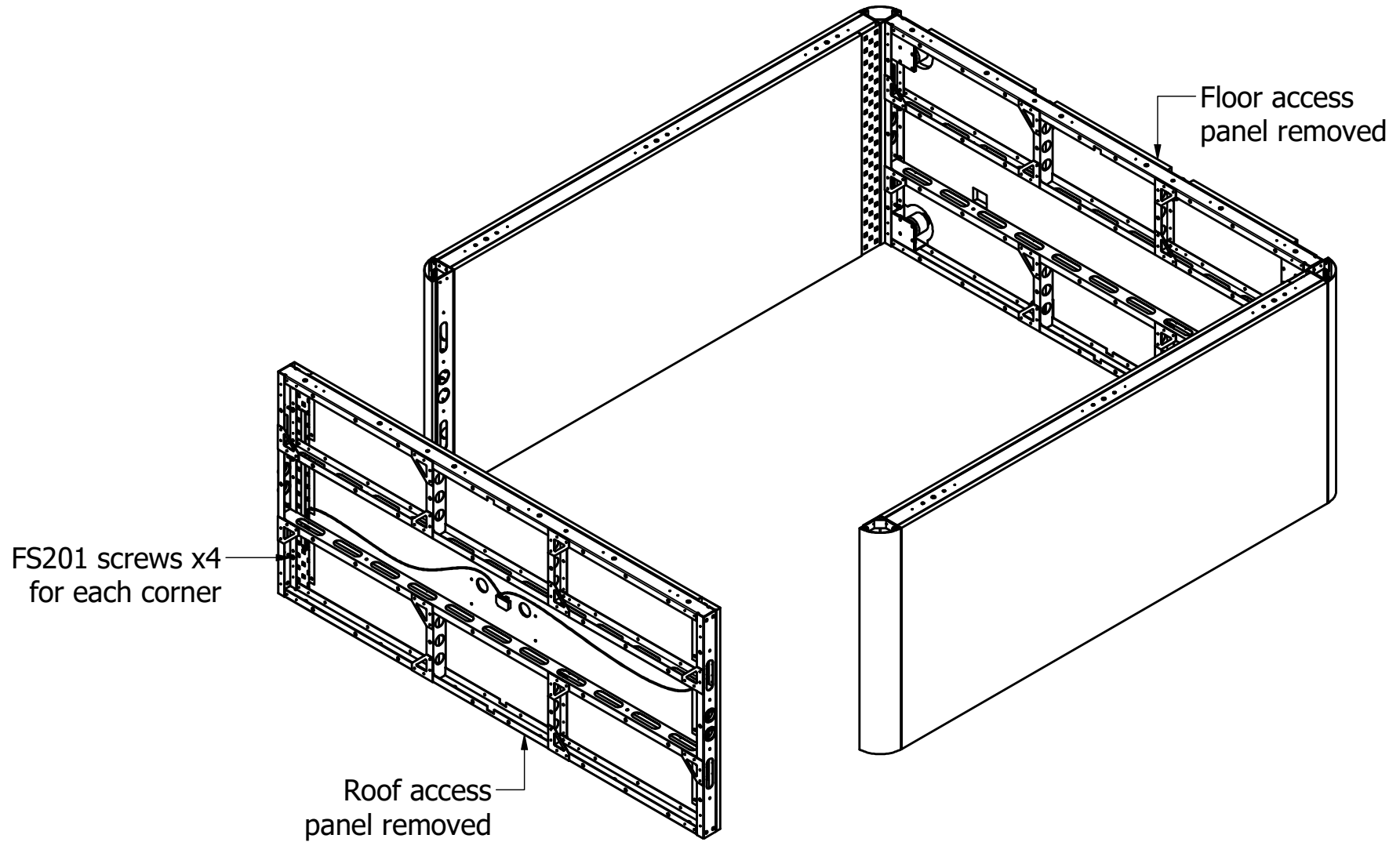

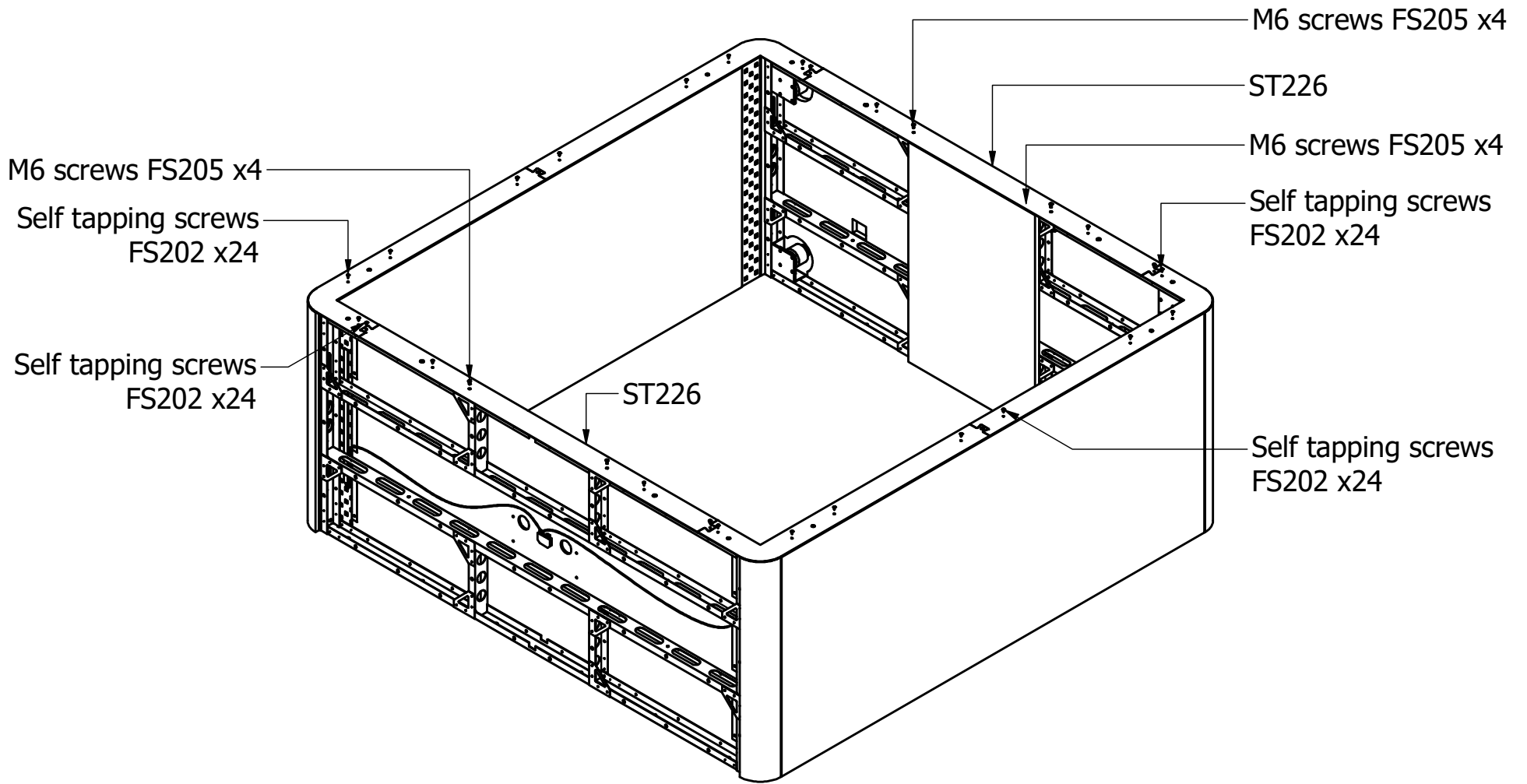

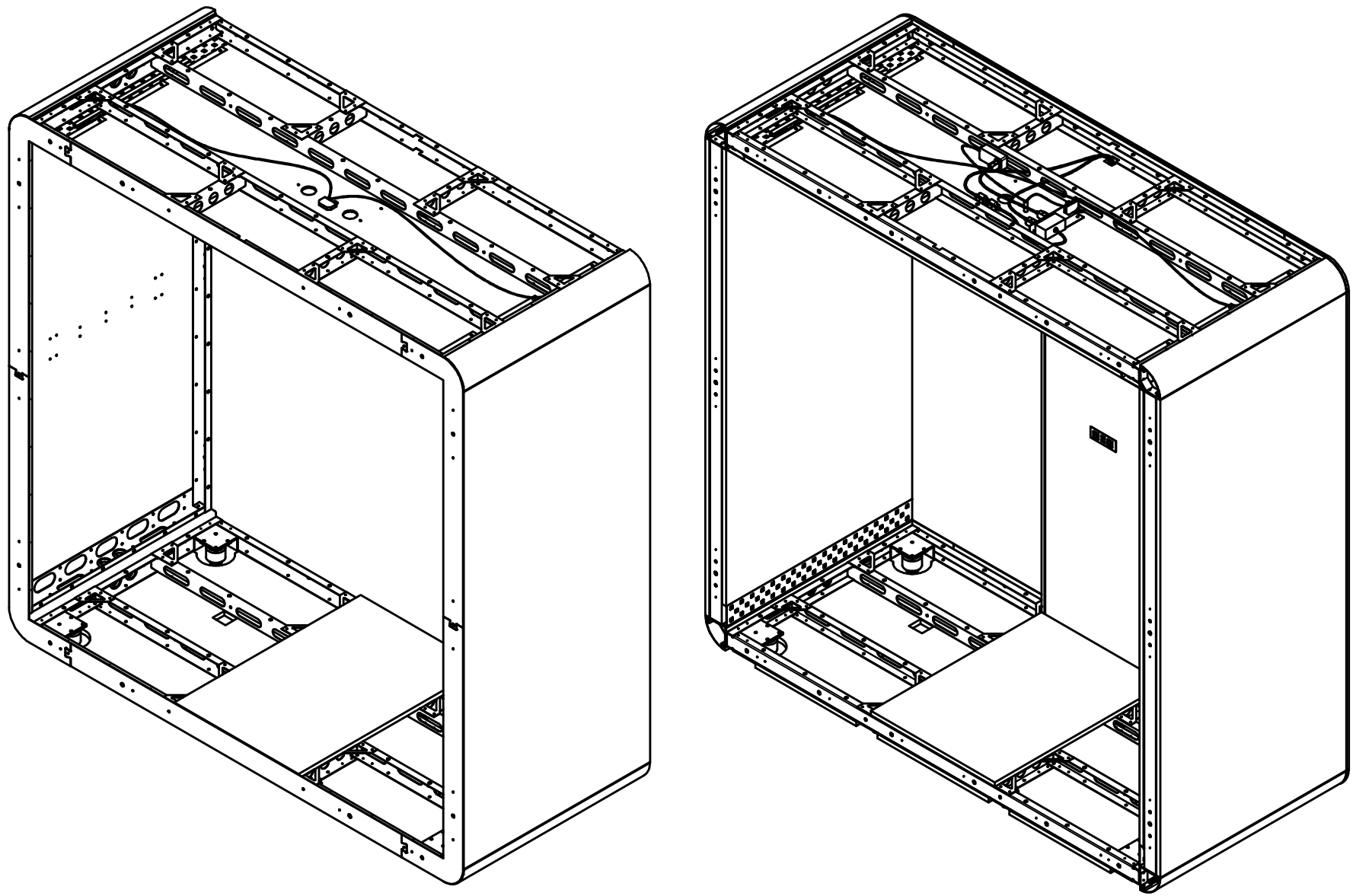

Ensure levelers have been retracted so that wheels are exposed. This will allow the unit to be rolled into its final installation location. Then level the unit. Remove inner skin panels. Join both cabins together. Connect them using self-tapping screws FS202 x28

Kteam\_GU\_P18

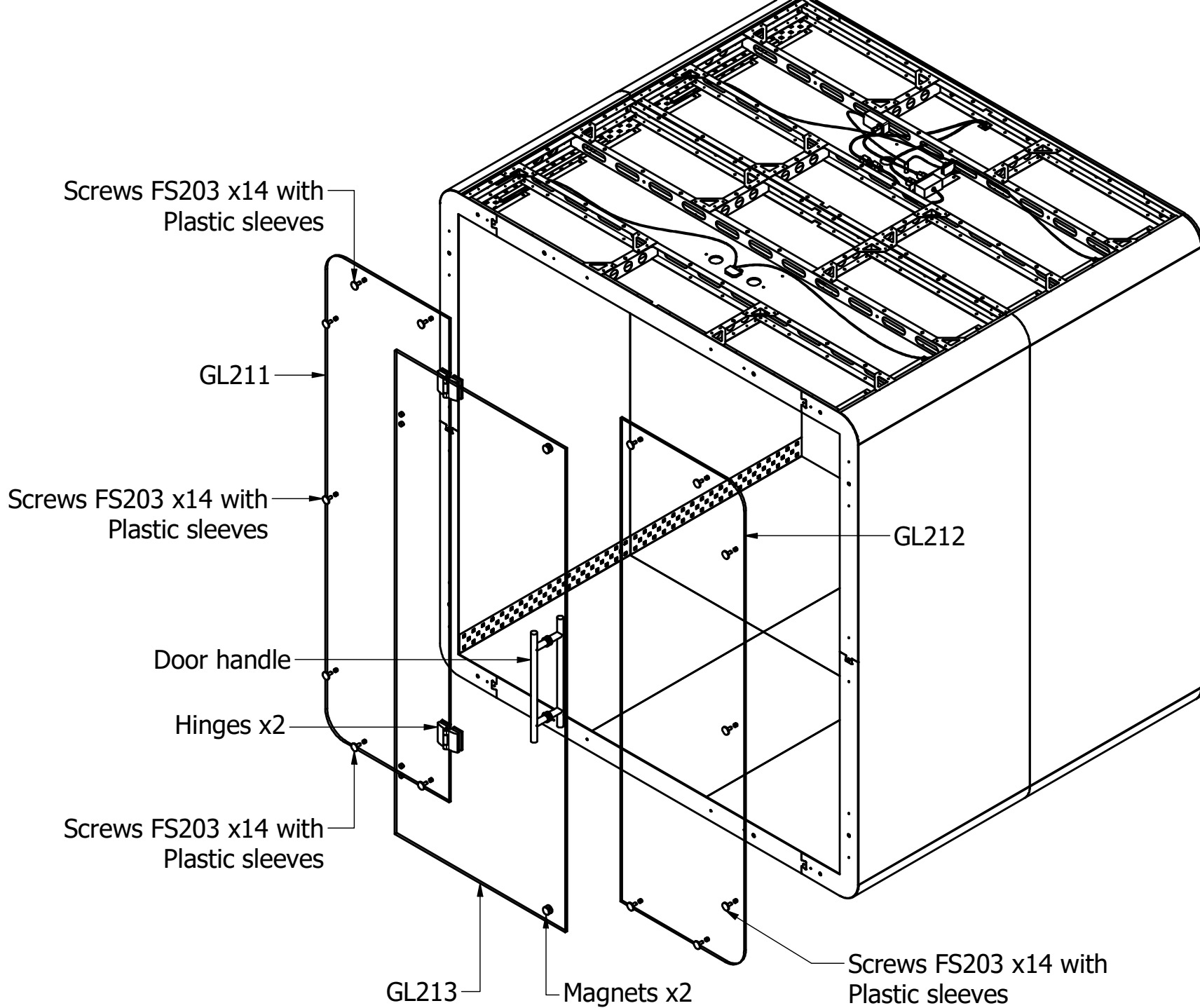

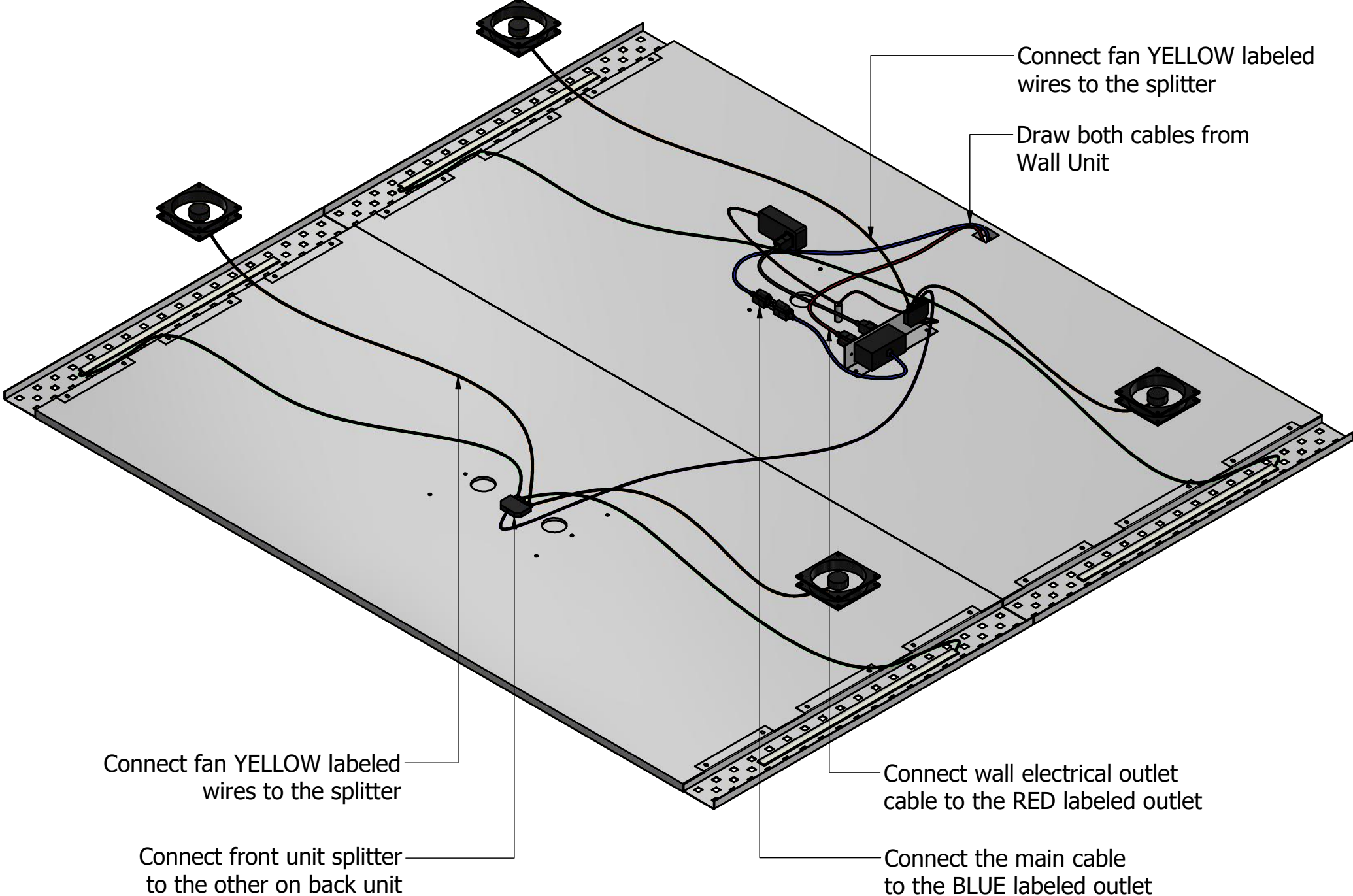

Connect fan YELLOW labeled wires to the splitter

Draw both cables from Wall Unit

Connect fan YELLOW labeled wires to the splitter

Connect front unit splitter to the other on back unit

Connect wall electrical outlet cable to the RED labeled outlet

Connect the main cable to the BLUE labeled outlet