

ASSEMBLY GUIDE

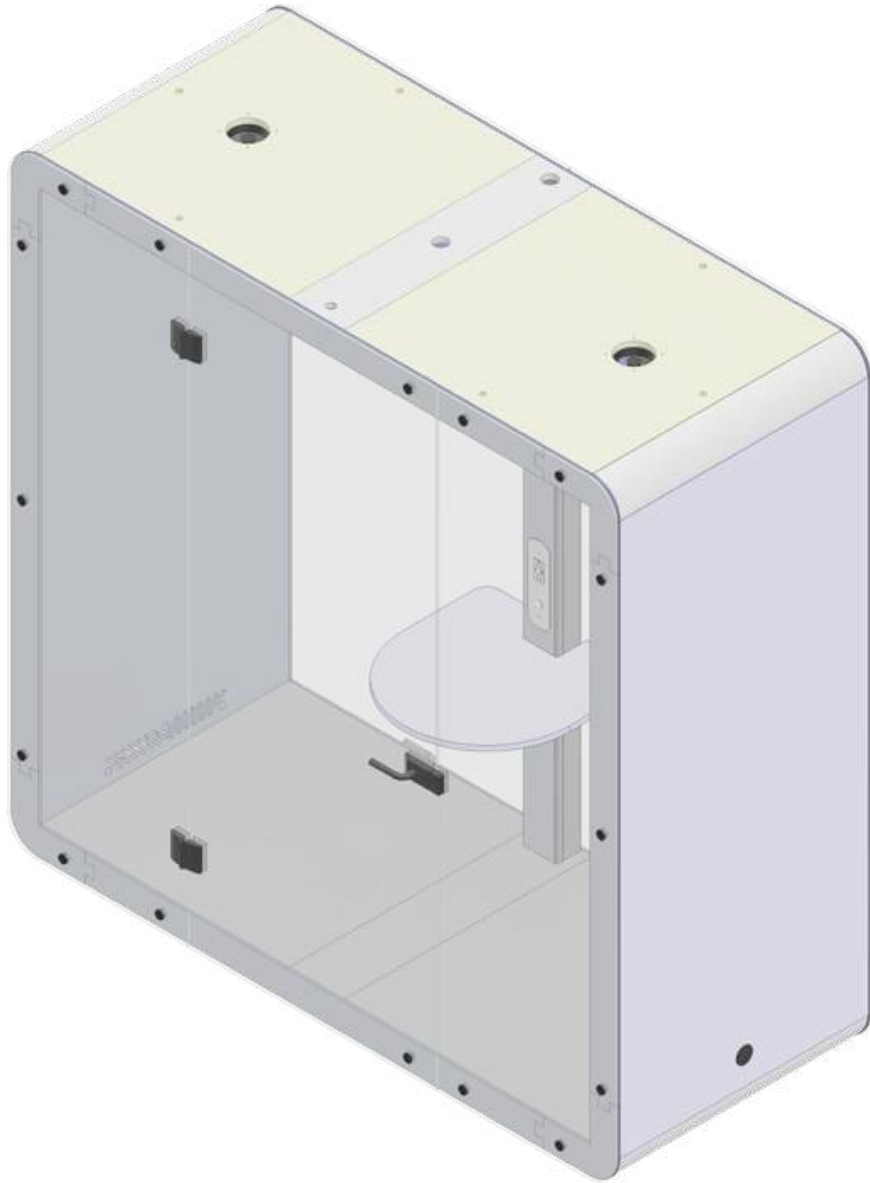

Kwe Signature



FS201 x 30
Euro screw



FS203 x 48
Self tapping screw



FS205 x 6
Wood screw



FS212 x 2
Door magnet set



FS213 x 28
M10 stand-off cap set



FS208 x 10
M10 machine screw
(x18 Kwe plus)



Stand-off cap key
x 2

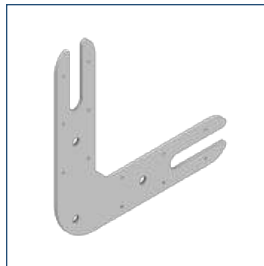

ST335 x 4
Units assembly
corner bracket

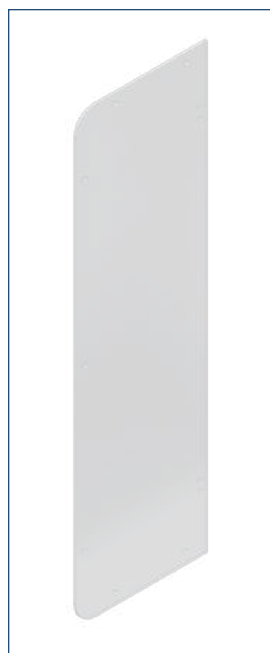

GL321 x 1
Hinges side of the front glass panel

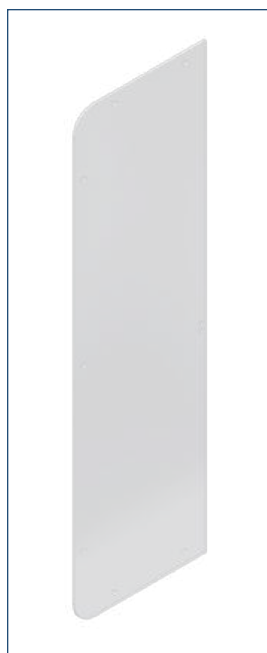

GL322 x 1
Receiving side of the front glass panel



GL323 x 1
Glass door

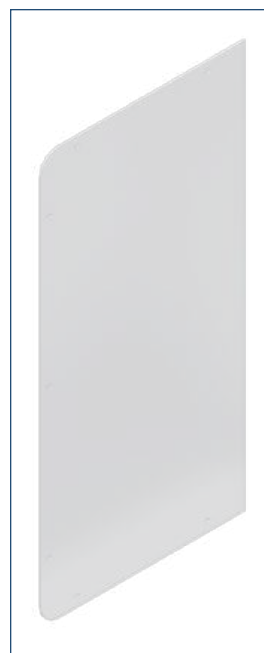

GL324 x 2
Rear glass panel

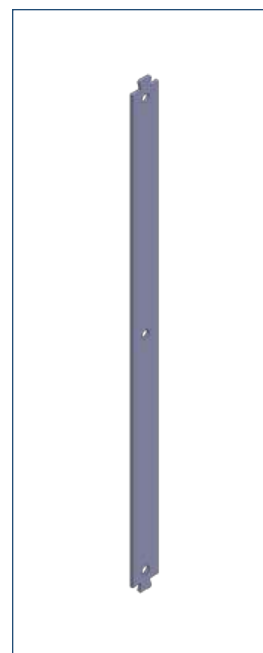

FT304 x 4
Acoustic cladding

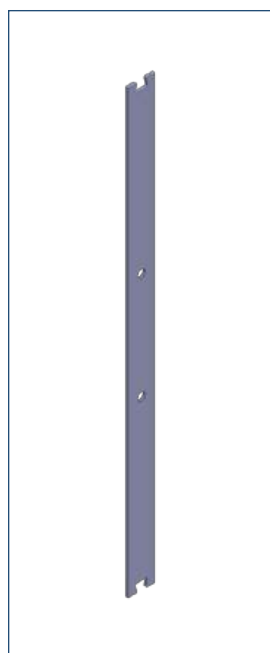

FT307 x 2
Acoustic cladding

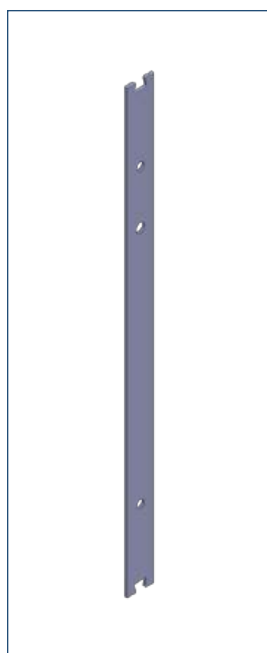

FT308 x 2
Acoustic cladding

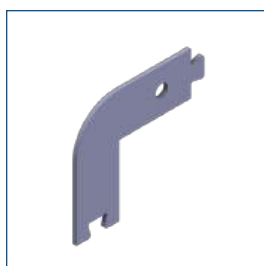

FT301 x 8
Acoustic cladding



A_HW203 x 2
Door hinge x 2

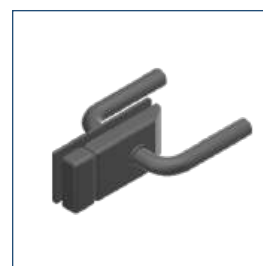

A_HW301 x 1
Door handle x 1

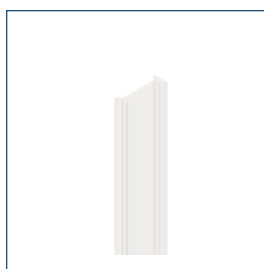

GA203 x 1
Butt glass gasket



ST329 x 1
Foot step guard L80"

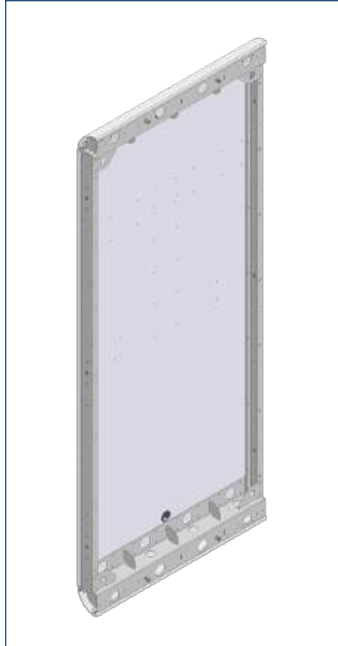

U_WL302 x 2
Wall unit

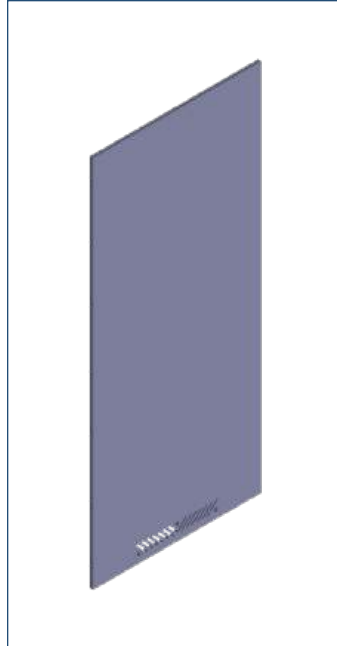

A_IN301 x 2
Acoustic interior panel

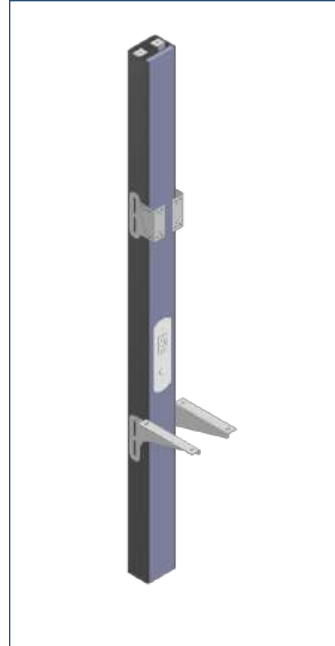

A_CN301
Central console assembly

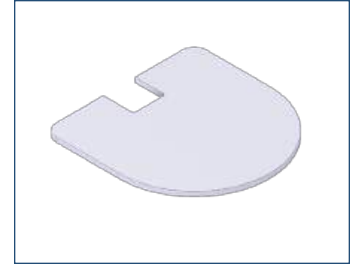

AC301 x 1
Work top

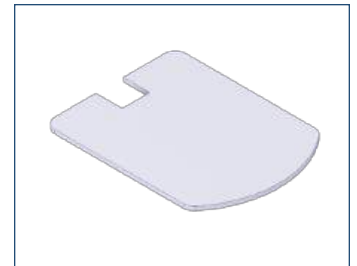

AC304 x 1
Work top (Kwe plus)

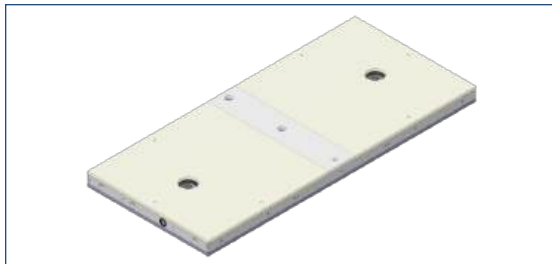

U_CL303 x 1
Ceiling unit (console assembly)

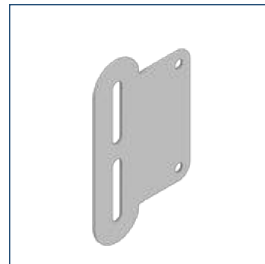

ST357 x 2
LCD mount bracket
by request

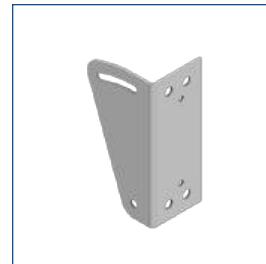

ST358 x 2
LCD mount bracket
by request



AC219 x 1
Supported leg
(Kwe plus)

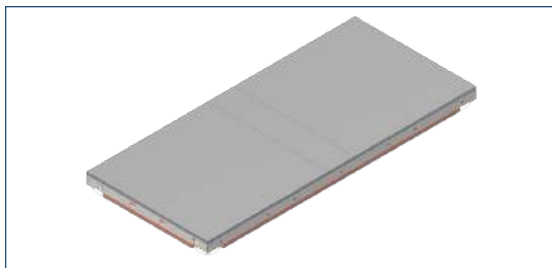

U_BS303 x 1
Base unit (console assembly)

Intro (assembly scenario)

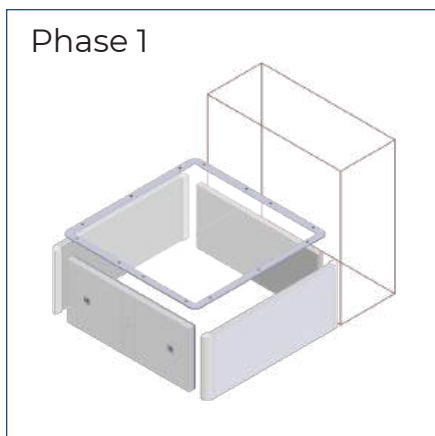

Rear segment assembly lay out on the ground. Remove acoustic interior panels

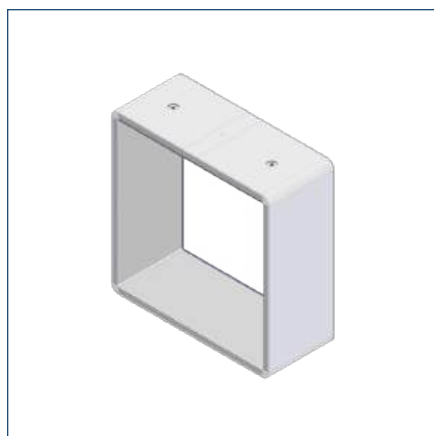

Raise up vertically assembled segment and locate properly

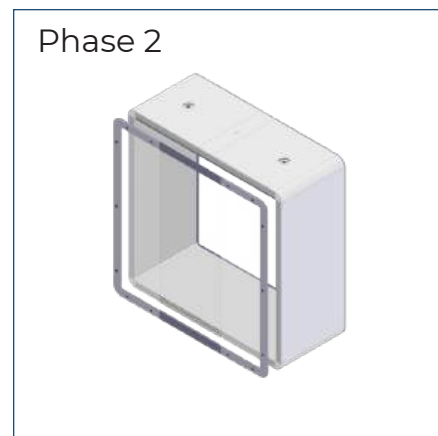

Assemble front glass panels
Level the unit

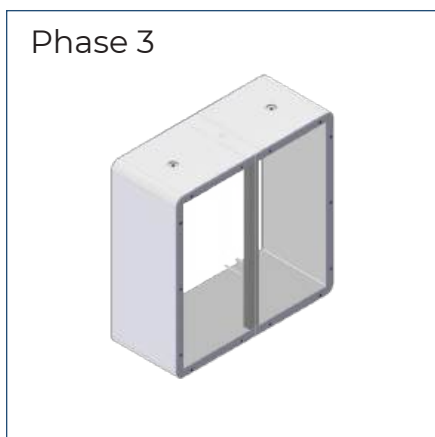

Attach central console and cross
connect the wires

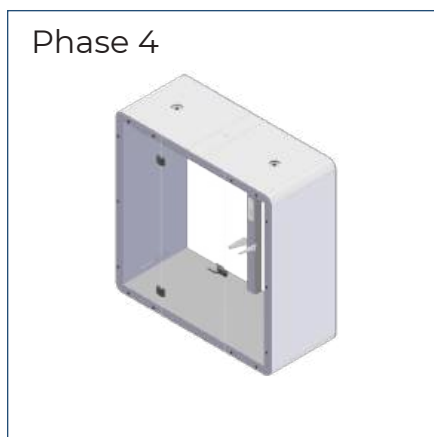

Assemble front glass door
Attach acoustic interior panels

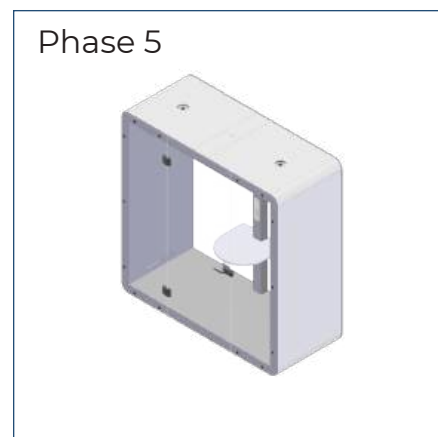

Mount work top, clean product

Wall units preparation

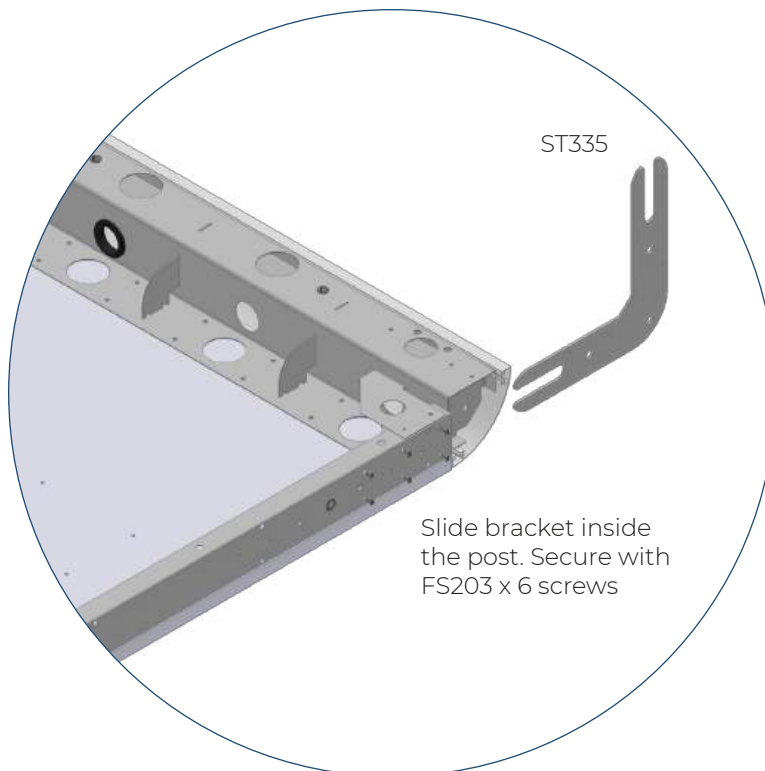

- lay out both wall units on the ground with “rear” side facing up
- slide in corner brackets and secure with FS203 screws on “rear” side only
- attach ceiling unit, ensuring “rear” side is facing up
- secure ceiling to wall using FS208 bolts.

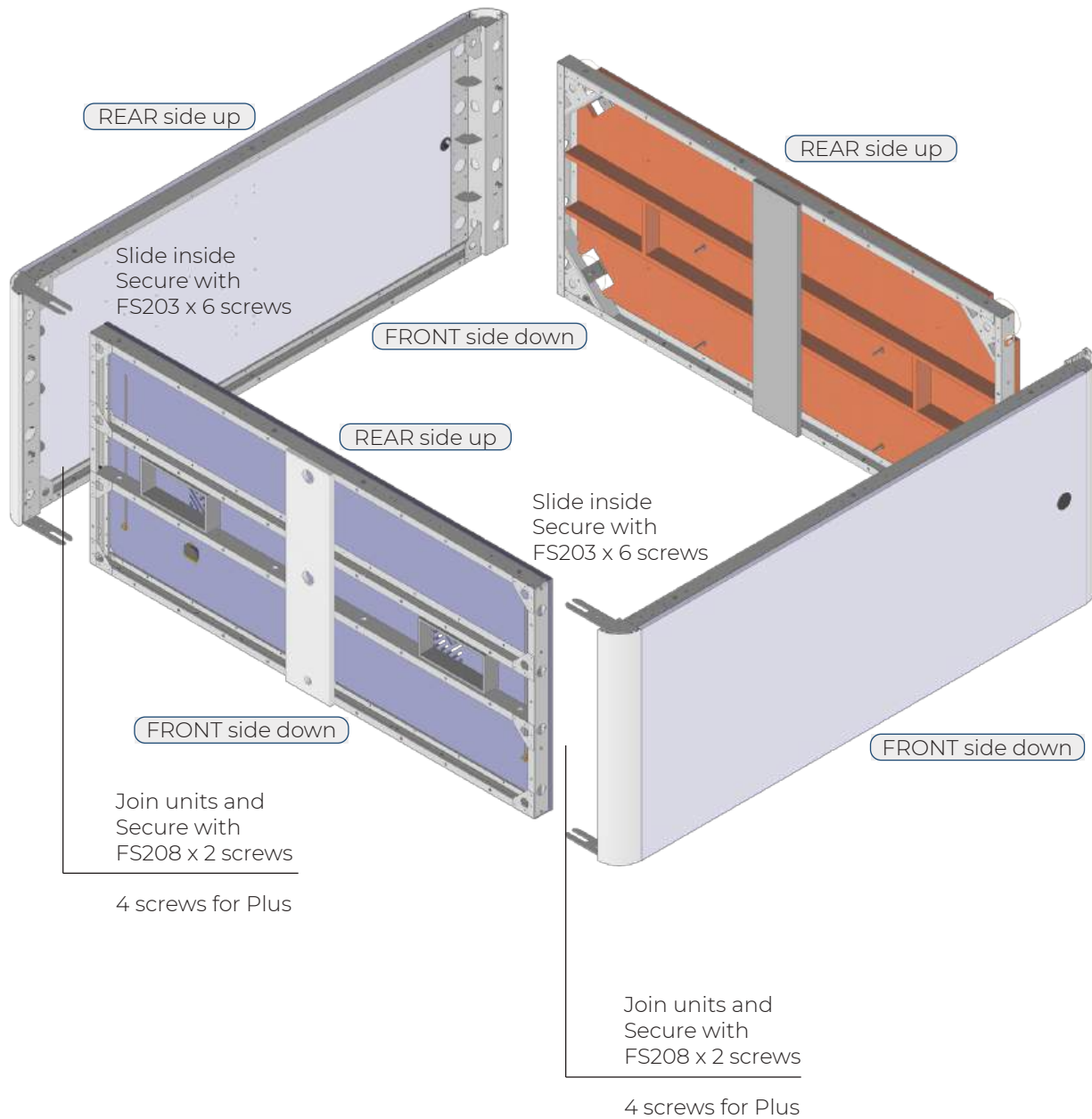

- while still on ground, lay the felt acoustic border on the edges of the unit, secure from inside with FS201 euro screws
- place rubber grommets in all the holes

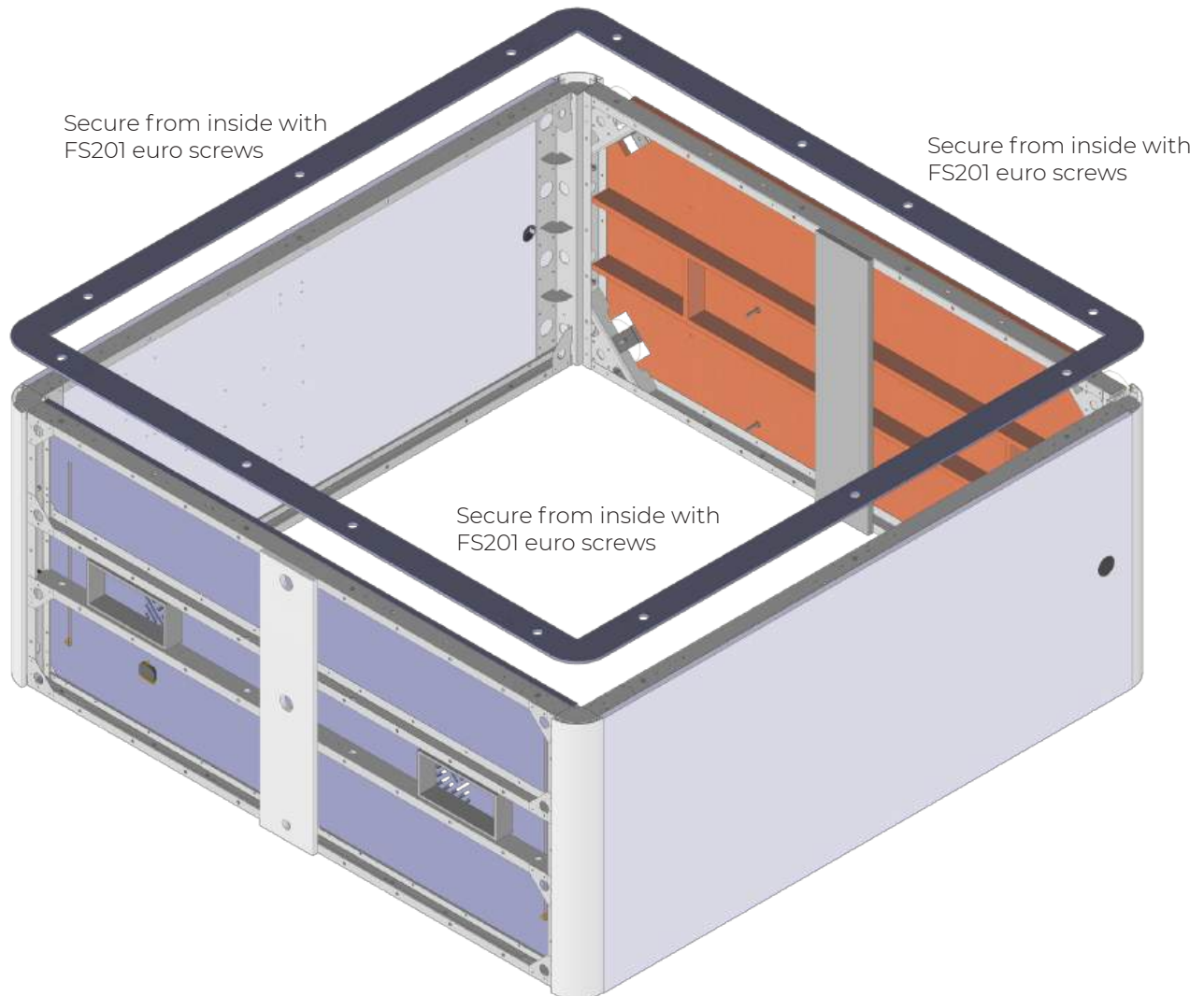

- attach 1 piece of rear glass to the unit and secure using FS213 screws with stand-off cap
- attach butt glass gasket to the edge of glass
- place other rear glass panel on the unit and secure using FS213 screws with stand-off cap

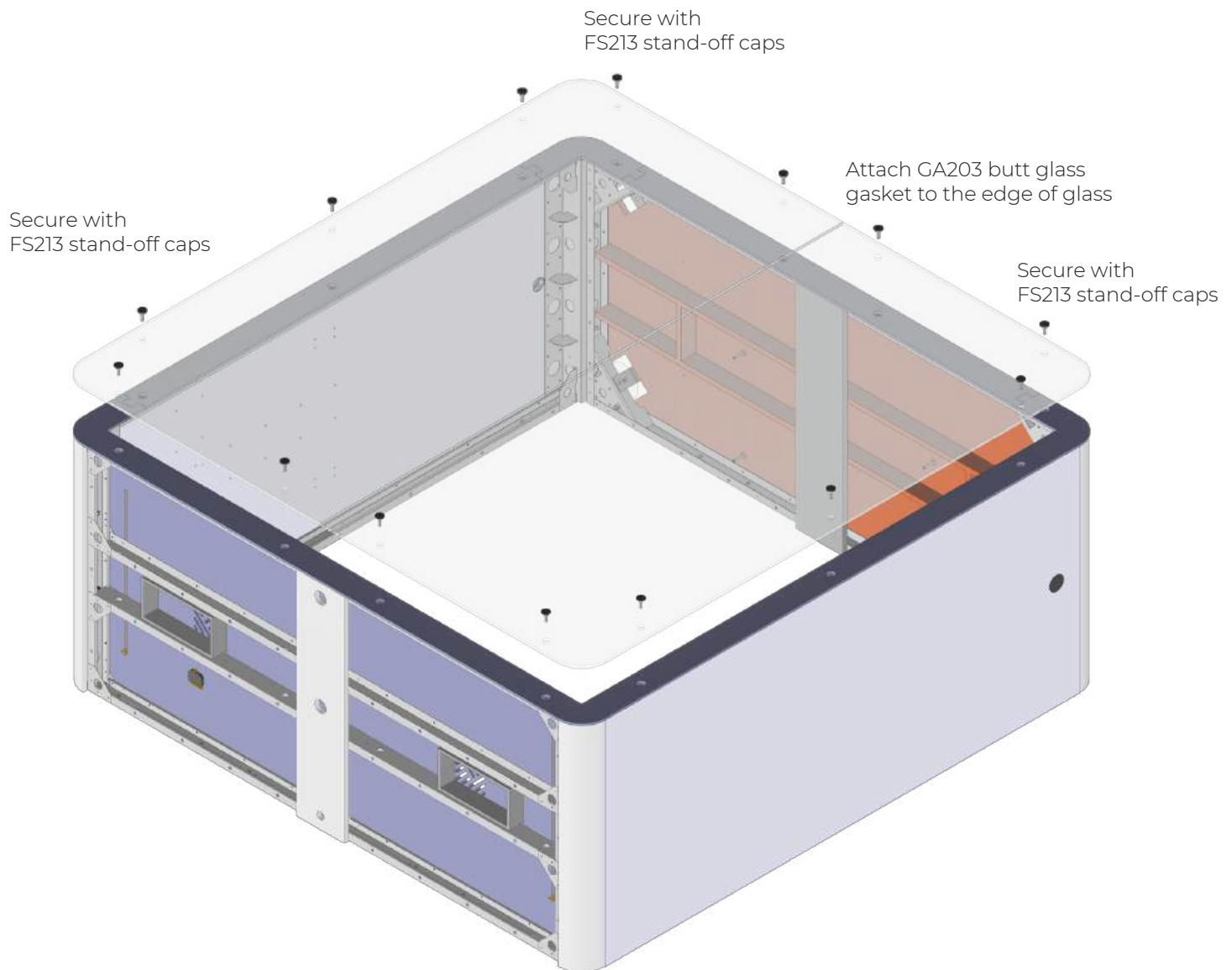

- adjust the glass and felt acoustic borders as needed, and tighten all FS213 screws with stand off caps
- stand the unit up vertically
- secure corner brackets with FS203 screws on “front” side

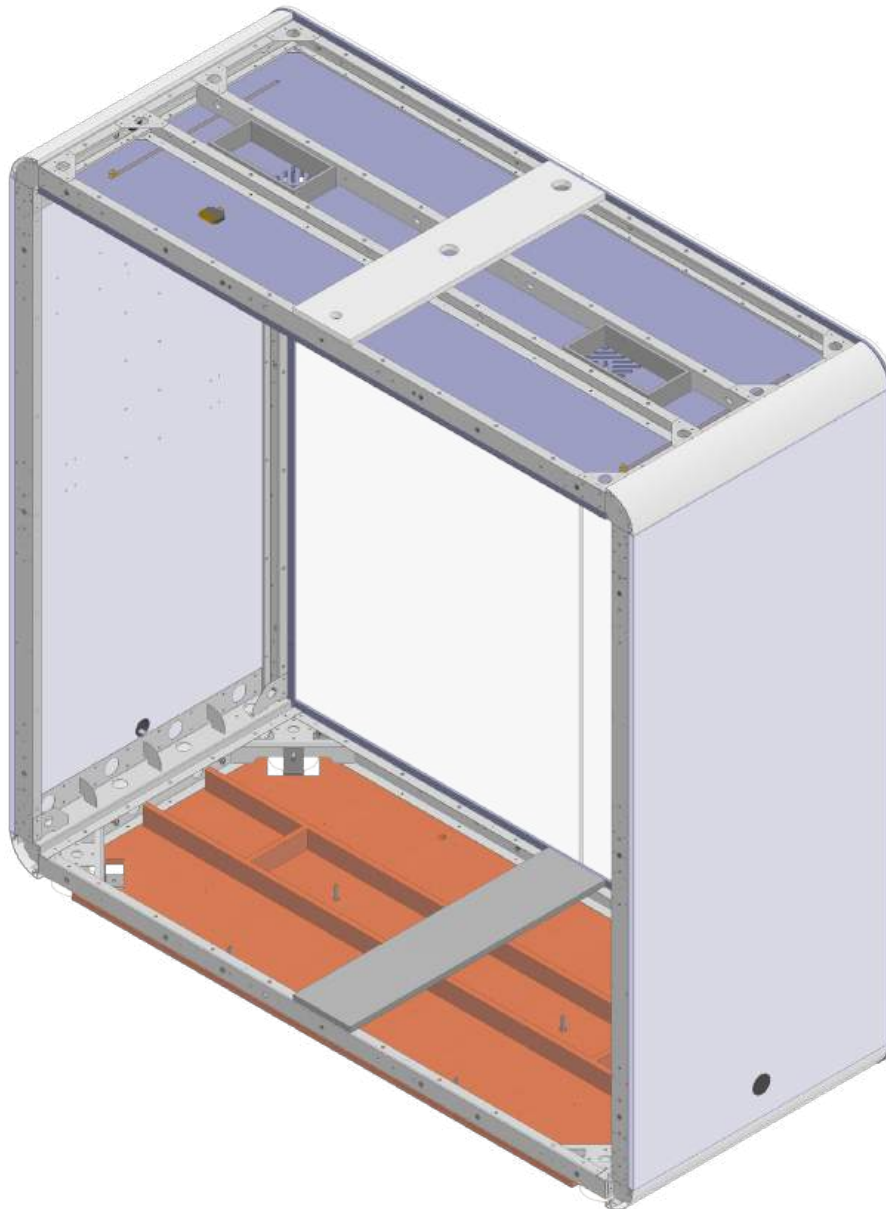

- attach the felt acoustic border on the edges of the unit, secure from inside with FS201 euro screws
- place rubber grommets in all the holes

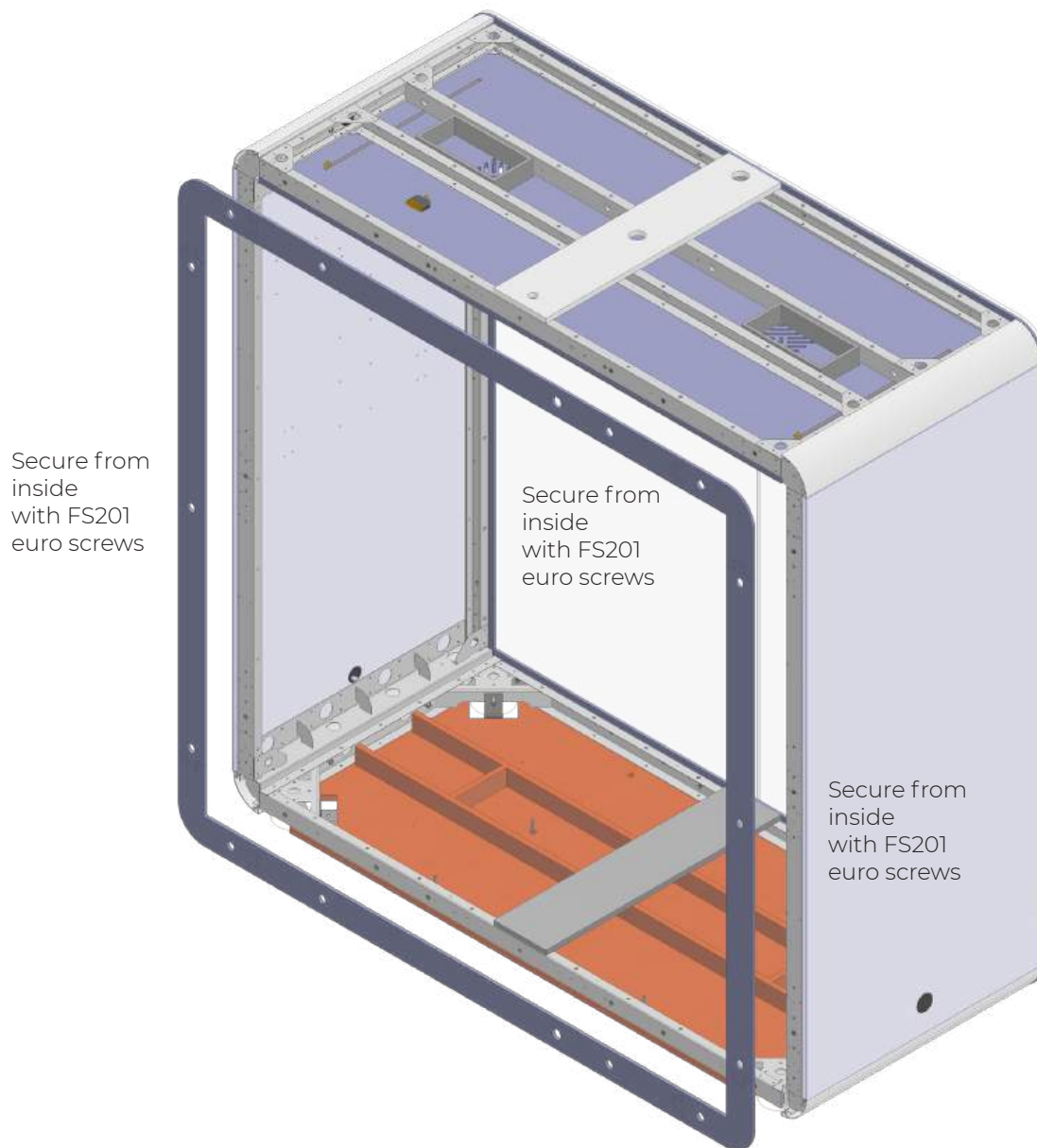

- attach 1 piece of front sidelight glass to the unit and secure using FS213 screws with stand-off cap
- place other front sidelight glass panel on the unit and secure using FS213 screws with stand-off cap
- start to level the unit using the casters leveler
- ensure that the booth is plumb vertically, and tighten all FS213 screws with stand off caps

NOTE - DOOR SWING DIRECTION:

When installing the front glass, take note of the hinge hole placement in the 2 front glass segments. Install the glass segments accordingly to determine proper door swing direction.

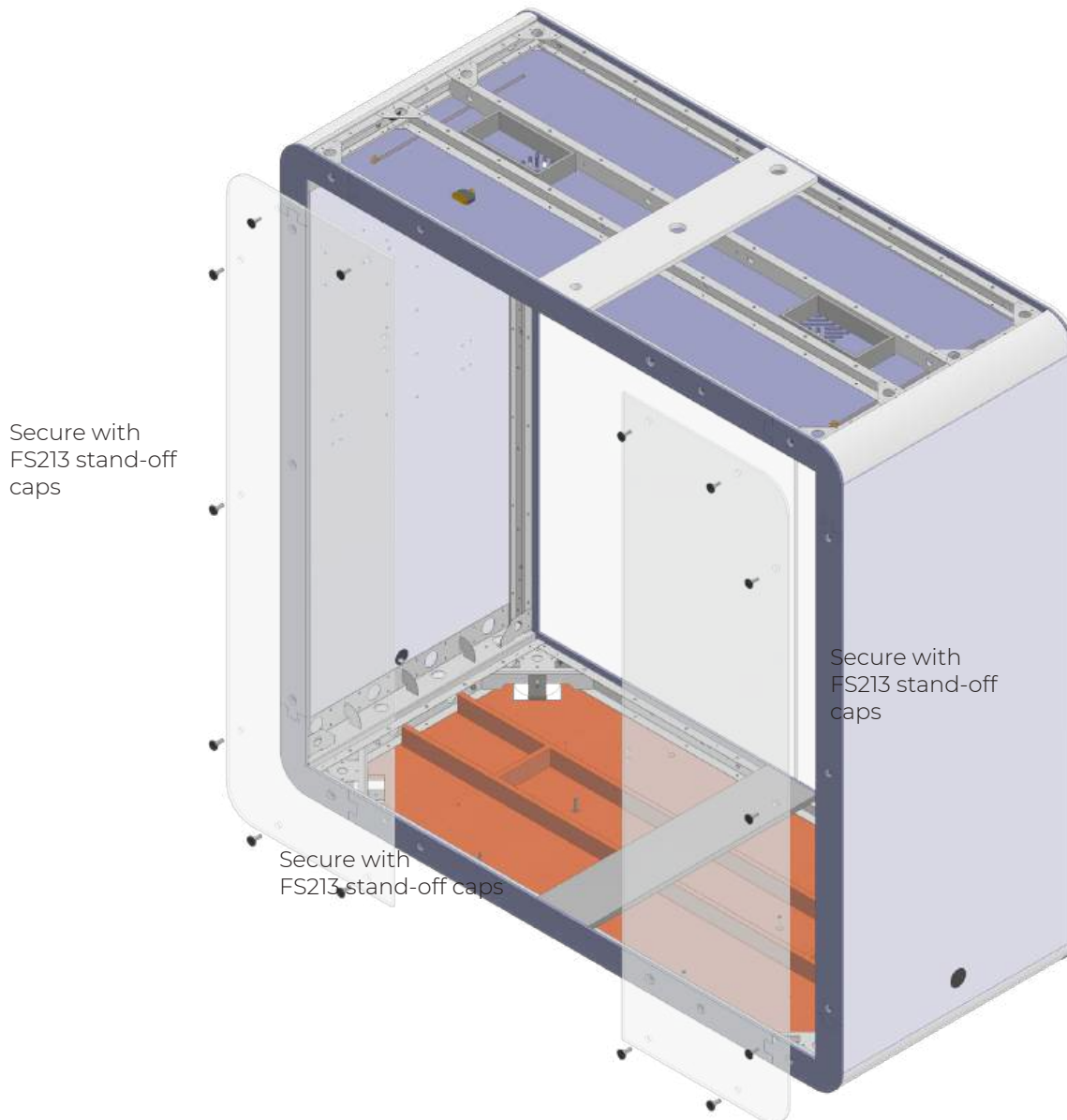

- locate central console (AL211 aluminum profile) in the middle of booth close to rear glass panel
- run output wires and input cable through the ceiling
- snap face panel (AL212 aluminum profile with mount power hub).
- mount console using FS205 screws
- mount work top cantilivers using FS208 - M10 machine screws



Secure from inside with
FS205 screws



Secure from inside with
FS205 screws

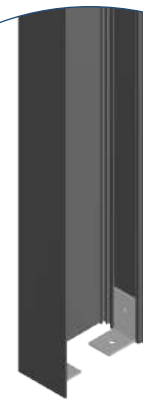

- run output wires and input cable through the ceiling
- connect wires to the splitter at the ceiling
- connect lights and speakers (optional) to the splitter
- run input cable inside the base down through plastic cap out
- put the roof panels on top and connect all fans to the splitter

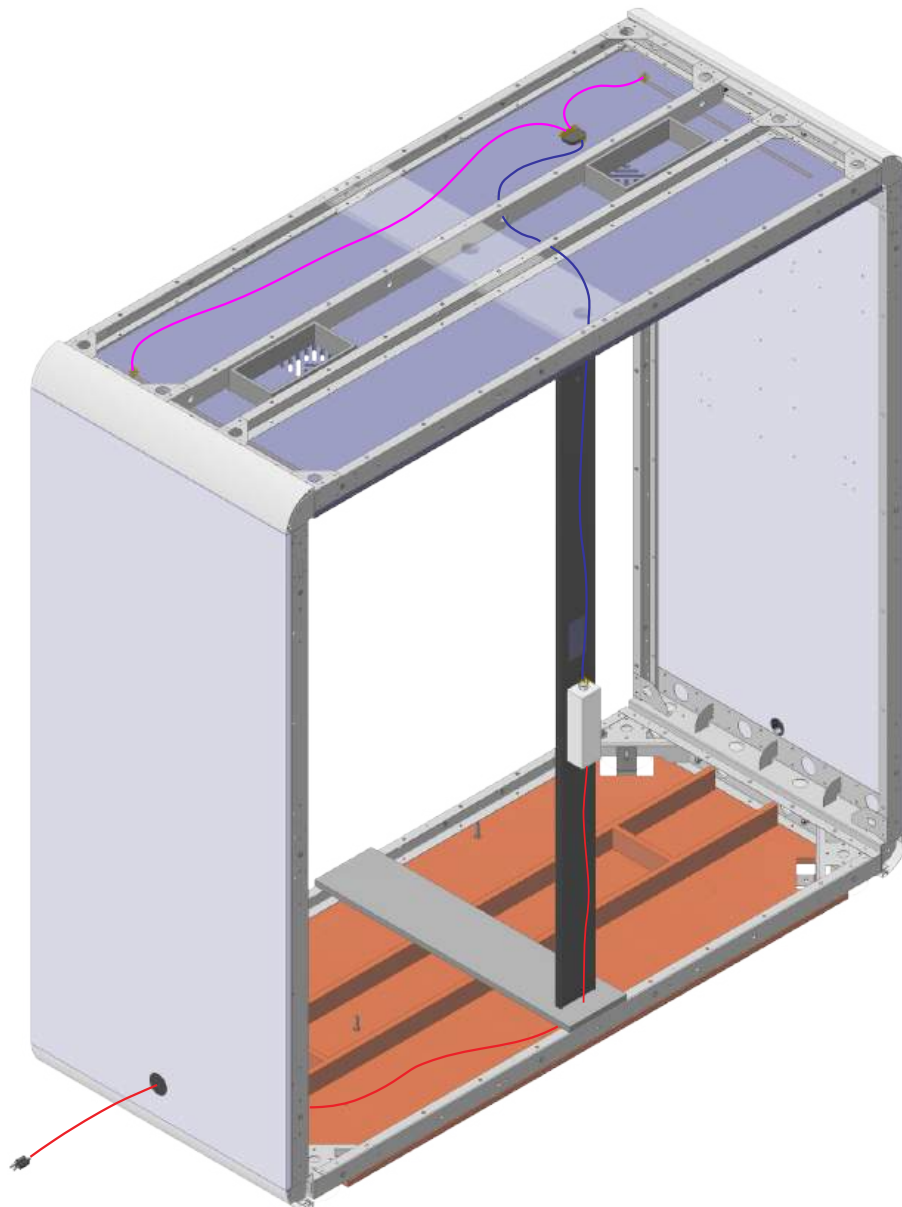

Once your side glass is installed you are able to mount your door. Be sure to install the silicon sleeves on every screw that goes through the glass unit.

Step 1: Get one hinge and one back plate with silicon sleeve and rubber spacer. Place the back plate to the inside of the unit where the pre drilled hole is located in glass and place the hinge on the exterior side of the same holes. Use screws provided in the hinge box to fasten the two pieces together. Do not over tighten at this point, leave it so you have some room to adjust the door. Do the same to install the second hinge.

Step 2: Bring the door up to both hinges and repeat steps to mount the door glass to the hinge. Snug the door to the hinges while supporting the door. Have one person inside the unit and one person on the exterior of the unit. Gently close the door making sure not to chip or mar the glass. Check for alignment and level while still supporting the door and once satisfied have the person on the interior tighten the screw M6 .

Step 3: Install cover plate on the interior to the glass backer plate use the Allan key provided in the hinge box to install this plate.

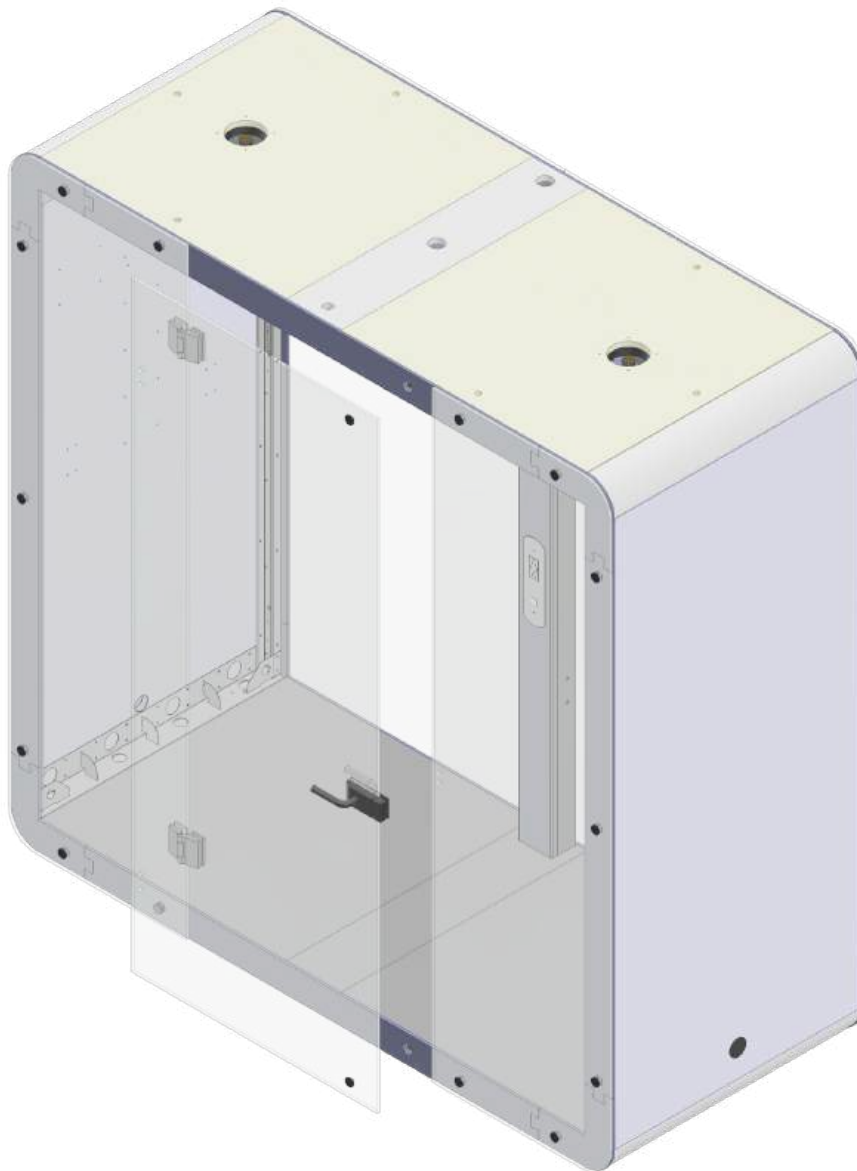

- attach interior acoustic panels
- mount work top supported cantilevers to console
- mount supported leg using wood screws (Kwe plus)

