



Because Privacy Matters



Kubebooth Technical Data Sheet - Kme Plus Floorless

Easy to Install

Size Overall - W: 88" - D: 48" - H: 88"
Inside - W: 80" - D: 47" - H: 84"

Weight
1150 lbs/527 kg

Glass
10mm clear tempered
Door - H: 88" x W: 32"
Rear Panel - H: 88" x W: 44"
Front Side Panels - H: 88" x W: 28"

Plug & Play

Acoustics
Class A noise reduction

Air Exchange
100 complete air changes per hour

Data Center
UL approved
1 USB A port, 1 USB C port
2 Simplex outlets
Motion detector (controls light & fan)

Light
12V LED light bar with magnet
570mm/pcs super light bar, 3500K, 12VDC

Sprinkler
Pre-engineered knockout hole for 3rd party sprinkler installation

Power Cord
10ft cord 120V/15Amp

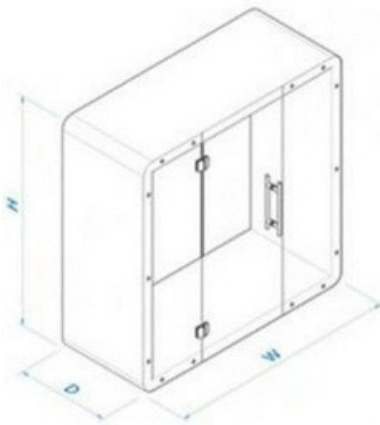

Wall Construction
Galvanized steel frames
Sound insulation in all cavities

Door Lock
Patch fit low noise- silent latch
Finishes

TFL surface
CARB certified (zero/low formaldehyde emissions)
Aluminum hardware painted

Reversible Door
Fully interchangeable left or right opening

Felt
Interior sound absorption panels
60% recyclable

Options
Seismic bracing
One touch LCD control panel
LCD TV mount bracing
White glass board - W: 34" x L: 30"
Personalized company branding
Ethernet ports
Bluetooth speaker
Frosted film glass
External fire extinguisher unit
Occupancy lights

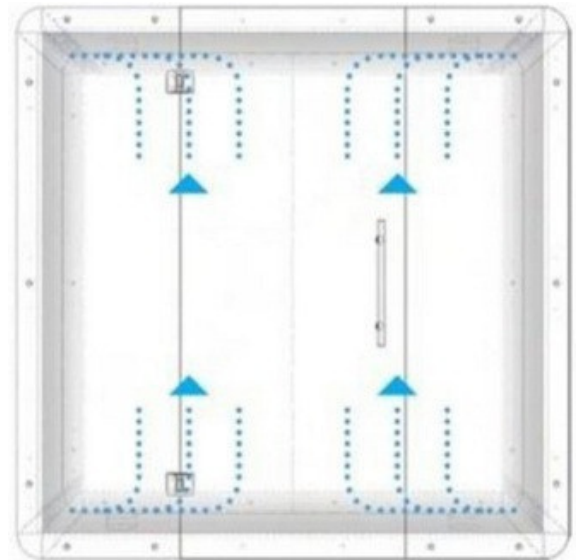

*Air Flow Diagram

Note: This privacy pod requires drilling to the floor as part of standard installation to ensure structural stability and user safety.

