



Because Privacy Matters



Kubebooth Technical Data Sheet - KSelfi Plus Floorless

Easy to Install

Plug & Play

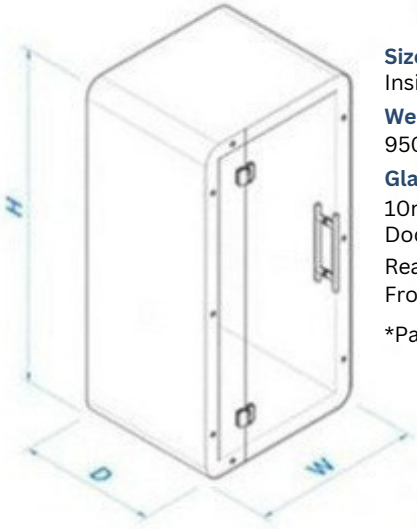

Size Overall - W: 56" - D: 48" - H: 88"
Inside - W: 48" - D: 47" - H: 84"

Weight
950 lbs/431 kg

Glass
10mm clear tempered
Door - H: 88" x W: 32"
Rear Panel - H: 88" x W: 44"
Front Side Panels - H: 88" x W: 12"

*Panel includes 2 piece glass

Acoustics Class A noise reduction

Air Exchange
100 complete air changes per hour

Data Center
UL approved 1 USB A port, 1 USB C port, 2 Simplex outlets
Motion detector (controls light & fan)

Light
12V LED light bar with magnet
570mm/pcs super light bar, 3500K, 12VDC

Sprinkler
Pre-engineered knockout hole for 3rd party sprinkler installation

Power Cord

10ft cord 120V/15Amp

Wall Construction

Galvanized steel frames
Sound insulation in all cavities

Finishes

TFL surface CARB certified (zero/low formaldehyde emissions) Aluminum hardware painted

Door Lock

Patch fit low noise- silent latch

Reversible Door

Fully interchangeable left or right opening

Felt

Interior sound absorption panels
60% recyclable

Options

Seismic bracing
One touch LCD control panel
LCD TV mount bracing
White glass board - W: 34" x L: 30"
Personalized company branding
Ethernet ports
Bluetooth speaker
Frosted film glass
External fire extinguisher unit
Occupancy lights

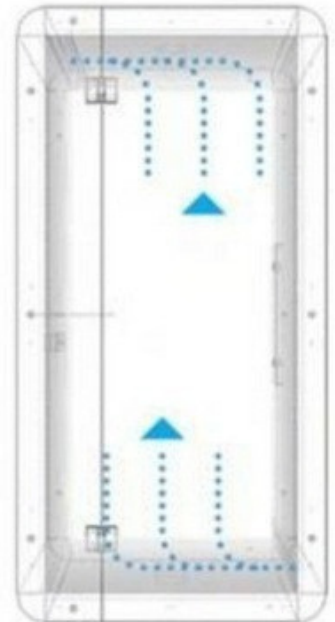

*Air Flow Diagram

Note: For your safety and optimal performance, this pod must be securely drilled to the floor during installation.

