



Because Privacy Matters



## Kubebooth Technical Data Sheet - Kwe

### Extendable

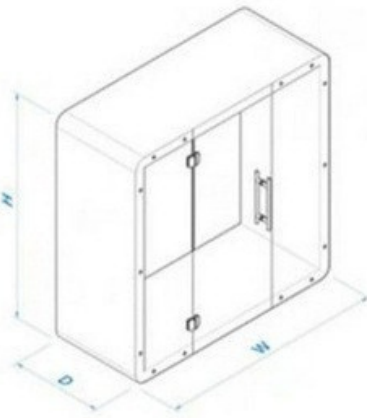

### Easy to Install

**Size Overall** - W: 88" - D: 37" - H: 88"  
**Inside** - W: 80" - D: 36" - H: 80"

**Weight**  
1200 lbs/544 kg

**Glass**  
10mm clear tempered  
Ceramic painted borders  
Door - H: 88" x W: 32"  
Rear Panels - H: 88" x W: 44"  
Front Side Panels - H: 88" x W: 28"

#### Reversible Door

Fully interchangeable left or right opening

#### Worktop

White or Black laminate wood worktop  
D shape L: 24" x W: 24"  
Installed at an optimum height of 28"

#### Felt

Interior sound absorption panels 60% recyclable

#### Options

Seismic bracing  
One touch LCD control panel  
LCD TV mount bracing  
White glass board - W: 34" x L: 30"  
Personalized company branding  
Ethernet ports  
Bluetooth speaker  
Frosted film glass  
External fire extinguisher unit  
Smart lock  
Occupancy lights

#### Wall Construction

Galvanized steel frames  
Sound insulation in all cavities

#### Finishes

D-pull handle  
TFL surface  
CARB certified  
(zero/low formaldehyde emissions)  
Aluminum hardware painted

#### Carpet

Shaw Commercial Philadelphia Ayers Hall II or equal  
Solution dyed polypropylene 28 oz, 10 gauge  
GreenGuard certified GLP8472  
<450 NBS smoke

#### Floor Ceiling

Substructure-rated MDF on unitized steel base.

### Moveable

#### Acoustics

NIC rating of 36 dB certified  
Noise cancellation technology

#### Air Exchange

100 complete air changes per hour

#### Data Center

UL approved  
1 USB A port, 1 USB C port  
2 Simplex outlets  
Motion detector (controls light & fan)

### Plug & Play

#### Mobility Kit

Includes casters with fasteners

#### Light

12V LED light bar with magnet  
570mm/pcs super light bar, 3500K, 12VDC

#### Sprinkler

Pre-engineered knockout hole for 3rd party sprinkler installation

#### Power Cord

10ft cord 120V/15Amp

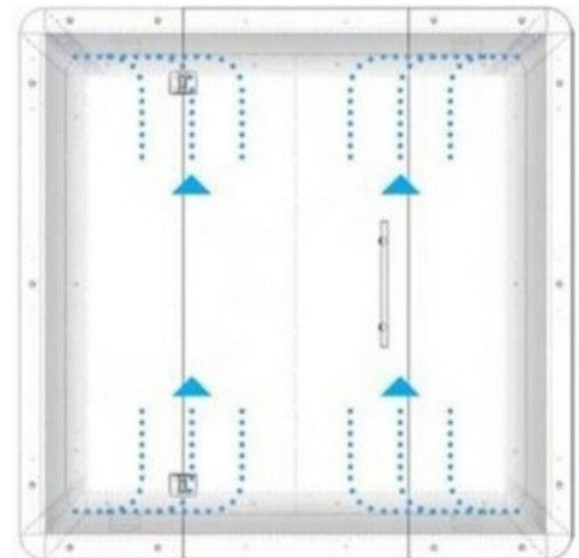

\*Air Flow Diagram

