



Because Privacy Matters



Kubebooth Technical Data Sheet - Kwe Plus

Extendable

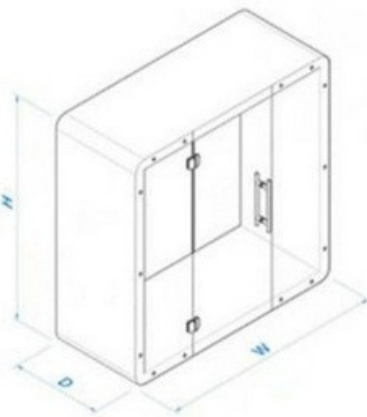

Easy to Install

Size Overall - W: 88" - D: 48" - H: 88"
Inside - W: 80" - D: 47" - H: 80"

Weight

1525 lbs/ 692 kg

Glass

10mm clear tempered
Ceramic painted borders
Door - H: 88" x W: 32"
Rear Panels - H: 88" x W: 44"
Front Side Panels - H: 88" x W: 28"

Reversible Door

Fully interchangeable left or right opening

Worktop

White or Black laminate wood worktop
D shape L: 31" x W:24"
Installed at an optimum height of 28"

Felt

Interior sound absorption panels 60% recyclable

Options

Seismic bracing
One touch LCD control panel
LCD TV mount bracing
White glass board - W: 34" x L: 30"
Personalized company branding
Ethernet ports
Bluetooth speaker
Frosted film glass
External fire extinguisher unit
Smart lock
Occupancy lights

Moveable

Acoustics

NIC rating of 36 dB certified
Noise cancellation technology

Air Exchange

100 complete air changes per hour

Data Center

UL approved
1 USB A port, 1 USB C port
2 Simplex outlets
Motion detector (controls light & fan)

Plug & Play

Mobility Kit

Includes casters with fasteners

Light

12V LED light bar with magnet
570mm/pcs super light bar, 3500K, 12VDC

Sprinkler

Pre-engineered knockout hole for 3rd party sprinkler installation

Power Cord

10ft cord 120V/15Amp

Wall Construction

Galvanized steel frames
Sound insulation in all cavities

Finishes

D-pull handle
TFL surface
CARB certified
(zero/low formaldehyde emissions)
Aluminum hardware painted

Carpet

Shaw Commercial Philadelphia
Ayers Hall II or equal
Solution dyed polypropylene 28 oz, 10 gauge
GreenGuard certified GLP8472
<450 NBS smoke

Floor Ceiling

Substructure-rated MDF on unitized steel base.

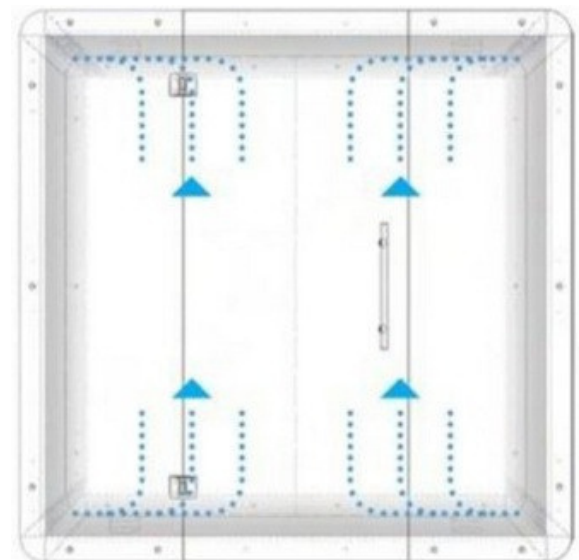

*Air Flow Diagram

