

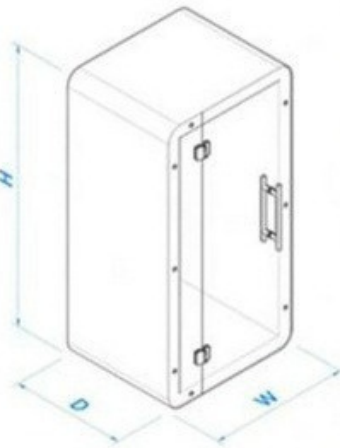

Because Privacy Matters



## Kubebooth Technical Data Sheet - KSelfi



### Easy to Install

**Size Overall** - W: 44" - D: 37" - H: 88"  
**Inside** - W: 36" - D: 36" - H: 80"

**Weight**  
800 lbs/362 kg

**Glass**  
10mm clear tempered  
Ceramic painted borders  
Door - H: 88" x W: 32"  
Rear Panel - H: 88" x W: 44"  
Front Side Panel - H: 88" x W: 12"

### Moveable

**Acoustics**  
NIC rating of 36 dB certified  
Noise cancellation technology  
**Air Exchange**  
100 complete air changes per hour  
**Data Center**  
UL approved  
1 USB A port, 1 USB C port  
2 Simplex outlets  
Motion detector (controls light & fan)

### Plug & Play

**Mobility Kit**  
Includes casters with fasteners

**Light**  
12V LED light bar with magnet  
570mm/pcs super light bar, 3500K, 12VDC

**Sprinkler**  
Pre-engineered knockout hole for 3rd party sprinkler installation

**Power Cord**  
10ft cord 120V/15Amp

**Wall Construction**  
Galvanized steel frames  
Sound insulation in all cavities

**Finishes**  
D-pull handle  
TFL surface  
CARB certified (zero/low formaldehyde emissions)  
Aluminum hardware painted

**Carpet**  
Shaw Commercial Philadelphia Ayers Hall II or equal  
Solution dyed polypropylene 28 oz, 10 gauge  
GreenGuard certified GLP8472 <450 NBS smoke

**Floor Ceiling**  
Substructure rated MDF on unitized steel base

**Reversible Door**  
Fully interchangeable left or right opening

**Worktop**  
White or black laminate wood worktop  
W: 20" x L: 12"  
Installed at an optimum height of 40"

**Felt**  
Interior sound absorption panels  
60% recyclable

**Options**  
Seismic bracing  
One touch LCD control panel  
LCD TV mount bracing  
White glass board - W: 34" x L: 30"  
Personalized company branding  
Ethernet ports  
Bluetooth speaker  
Frosted film glass  
External fire extinguisher unit  
Occupancy lights

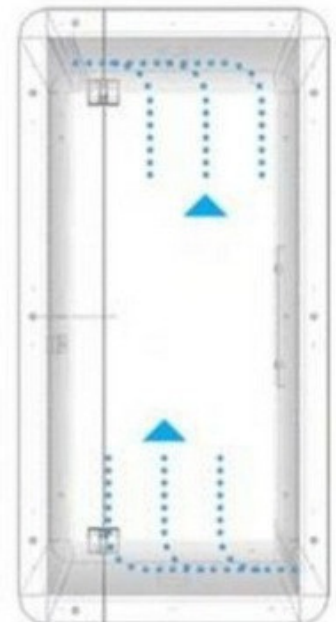

\*Air Flow Diagram





Because Privacy Matters



## Kubebooth Technical Data Sheet - KSelfi Plus

### Easy to Install

**Size Overall** - W: 56" - D: 48" - H: 88"  
**Inside** - W: 48" - D: 47" - H: 80"

**Weight**  
1000 lbs/453 kg

**Glass**  
10mm clear tempered  
Ceramic painted borders  
Door - H: 88" x W: 32"  
Front Side Panels - H: 88" x W: 12"

### Moveable

**Acoustics**  
NIC rating of 36 dB certified  
Noise cancellation technology

**Air Exchange**  
100 complete air changes per hour

**Data Center**  
UL approved  
1 USB A port, 1 USB C port  
2 Simplex outlets

### Plug & Play

**Mobility Kit**  
Includes casters with fasteners

**Light**  
12V LED light bar with magnet  
570mm/pcs super light bar, 3500K, 12VDC

**Sprinkler** Pre-engineered knockout hole for 3rd party sprinkler installation

**Power Cord**  
10ft cord 120V/15Amp

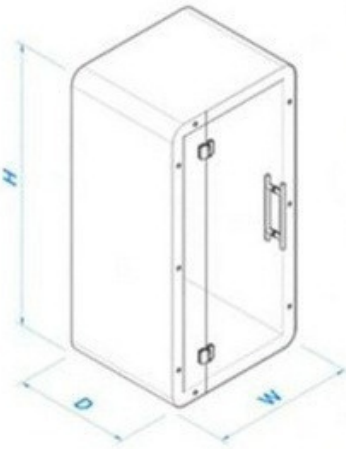

### Wall Construction

Galvanized steel frames  
Sound insulation in all cavities

### Finishes

D-pull handle  
TFL surface  
CARB certified  
(zero/low formaldehyde emissions)  
Aluminum hardware painted

### Carpet

Shaw Commercial Philadelphia Ayers Hall II or equal  
Solution dyed polypropylene 28 oz, 10 gauge  
GreenGuard certified GLP8472 <450 NBS smoke

### Floor Ceiling

Substructure rated MDF on unitized steel base

### Reversible Door

Fully interchangeable left or right opening

**Felt** Interior sound absorption panels 60% recyclable

### Options

Seismic bracing  
One touch LCD control panel  
LCD TV mount bracing  
White glass board - W: 34" x L: 30"  
Personalized company branding  
Ethernet ports  
Bluetooth speaker  
Frosted film glass  
External fire extinguisher unit  
Occupancy lights

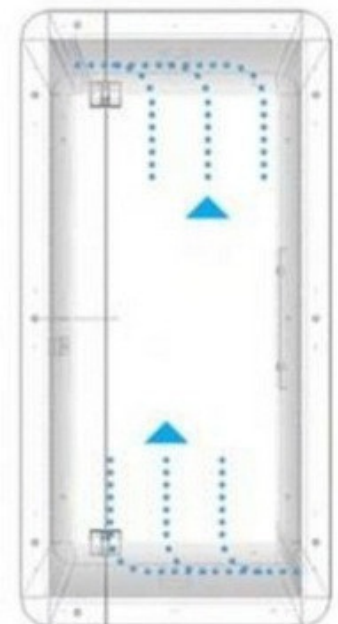

\*Air Flow Diagram





Because Privacy Matters



## Kubebooth Technical Data Sheet - Kme

### Easy to Install

**Size Overall** - W: 88" - D: 37" - H: 88"  
**Inside** - W: 80" - D: 36" - H: 80"

**Weight**  
1200 lbs/544 kg

**Glass**  
10mm clear tempered  
Ceramic painted borders  
Door - H: 88" x W: 32"  
Rear Panel - H: 88" x W: 44"  
Front Side Panels - H: 88" x W: 28"

**Reversible Door**  
Fully interchangeable left or right opening

**Floor Ceiling**  
Substructure-rated MDF on unitized steel base.

**Felt**  
Interior sound absorption panels  
60% recyclable

**Options**  
Seismic bracing  
One touch LCD control panel  
LCD TV mount bracing  
White glass board - W: 34" x L: 30"  
Personalized company branding  
Ethernet ports  
Bluetooth speaker  
Frosted film glass  
External fire extinguisher unit  
Occupancy lights

### Moveable

**Acoustics**  
NIC rating of 36 dB certified  
Noise cancellation technology

**Air Exchange**  
100 complete air changes per hour

**Data Center**  
UL approved  
1 USB A port, 1 USB C port  
2 Simplex outlets  
Motion detector (controls light & fan)

### Plug & Play

**Mobility Kit**  
Includes casters with fasteners

**Light**  
12V LED light bar with magnet  
570mm/pcs super light bar, 3500K, 12VDC

**Sprinkler** Pre-engineered knockout hole for 3rd party sprinkler installation

**Power Cord**  
10ft cord 120V/15Amp

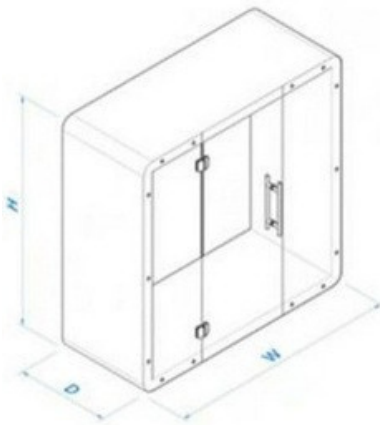

**Wall Construction**  
Galvanized steel frames  
Sound insulation in all cavities

**Finishes**  
D-pull handle  
TFL surface  
CARB certified (zero/low formaldehyde emissions)  
Aluminum hardware painted

**Carpet**  
Shaw Commercial Philadelphia Ayers Hall II or equal  
Solution dyed polypropylene 28 oz, 10 gauge  
GreenGuard certified GLP8472 <450 NBS smoke

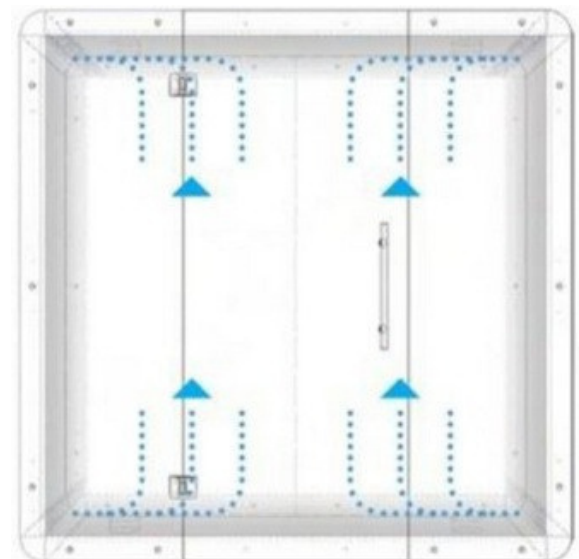

\*Air Flow Diagram





Because Privacy Matters



## Kubebooth Technical Data Sheet - Kme Plus

### Easy to Install

**Size Overall** - W: 88" - D: 48" - H: 88"  
**Inside** - W: 80" - D: 47" - H: 80"

**Weight**  
1525 lbs/692 kg

**Glass**  
10mm clear tempered  
Ceramic painted borders  
Door - H: 88" x W: 32"  
Rear Panel - H: 88" x W: 44"  
Front Side Panels - H: 88" x W: 28"

**Reversible Door**  
Fully interchangeable left or right opening

**Floor Ceiling**  
Substructure-rated MDF on unitized steel base.

**Felt**  
Interior sound absorption panels  
60% recyclable

**Options**  
Seismic bracing  
One touch LCD control panel  
LCD TV mount bracing  
White glass board - W: 34" x L: 30"  
Personalized company branding  
Ethernet ports  
Bluetooth speaker  
Frosted film glass  
External fire extinguisher unit  
Occupancy lights

### Moveable

**Acoustics**  
NIC rating of 36 dB certified  
Noise cancellation technology

**Air Exchange**  
100 complete air changes per hour

**Data Center**  
UL approved  
1 USB A port, 1 USB C port  
2 Simplex outlets  
Motion detector (controls light & fan)

### Plug & Play

**Mobility Kit**  
Includes casters with fasteners

**Light**  
12V LED light bar with magnet  
570mm/pcs super light bar, 3500K, 12VDC

**Sprinkler** Pre-engineered knockout hole for 3rd party sprinkler installation

**Power Cord**  
10ft cord 120V/15Amp

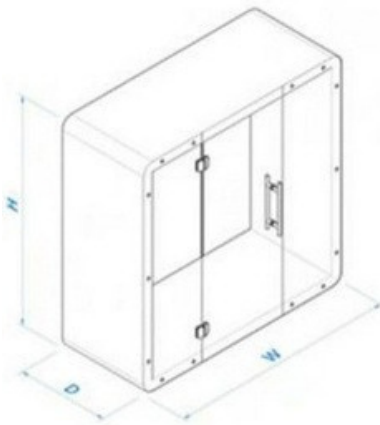

**Wall Construction**  
Galvanized steel frames  
Sound insulation in all cavities

**Finishes**  
D-pull handle  
TFL surface  
CARB certified (zero/low formaldehyde emissions)  
Aluminum hardware painted

**Carpet**  
Shaw Commercial Philadelphia Ayers Hall II or equal  
Solution dyed polypropylene 28 oz, 10 gauge  
GreenGuard certified GLP8472 <450 NBS smoke

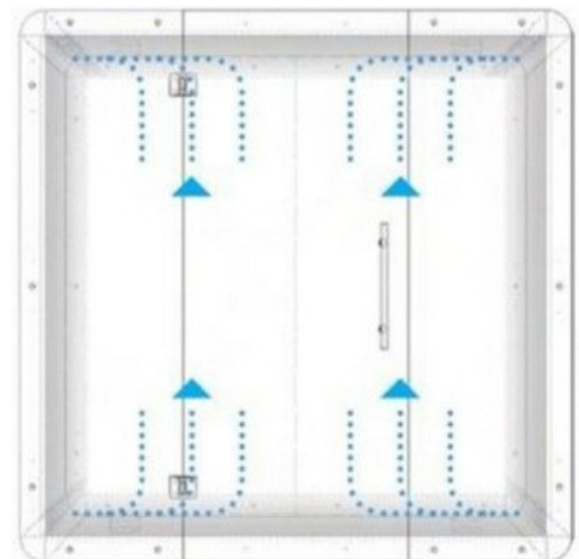

\*Air Flow Diagram





Because Privacy Matters



## Kubebooth Technical Data Sheet - Kwe

### Extendable

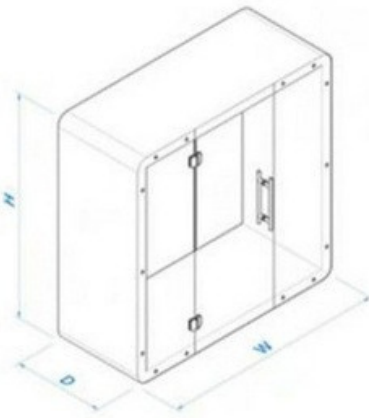

### Easy to Install

**Size Overall** - W: 88" - D: 37" - H: 88"  
**Inside** - W: 80" - D: 36" - H: 80"

**Weight**  
1200 lbs/544 kg

**Glass**  
10mm clear tempered  
Ceramic painted borders  
Door - H: 88" x W: 32"  
Rear Panels - H: 88" x W: 44"  
Front Side Panels - H: 88" x W: 28"

**Reversible Door**  
Fully interchangeable left or right opening

**Worktop**  
White or Black laminate wood worktop  
D shape L: 24" x W: 24"  
Installed at an optimum height of 28"

**Felt**  
Interior sound absorption panels 60% recyclable

**Options**  
Seismic bracing  
One touch LCD control panel  
LCD TV mount bracing  
White glass board - W: 34" x L: 30"  
Personalized company branding  
Ethernet ports  
Bluetooth speaker  
Frosted film glass  
External fire extinguisher unit  
Smart lock  
Occupancy lights

**Wall Construction**  
Galvanized steel frames  
Sound insulation in all cavities

**Finishes**  
D-pull handle  
TFL surface  
CARB certified  
(zero/low formaldehyde emissions)  
Aluminum hardware painted

**Carpet**  
Shaw Commercial Philadelphia  
Ayers Hall II or equal  
Solution dyed polypropylene 28 oz, 10 gauge  
GreenGuard certified GLP8472  
<450 NBS smoke

**Floor Ceiling**  
Substructure-rated MDF on unitized steel base.

### Moveable

**Acoustics**  
NIC rating of 36 dB certified  
Noise cancellation technology

**Air Exchange**  
100 complete air changes per hour

**Data Center**  
UL approved  
1 USB A port, 1 USB C port  
2 Simplex outlets  
Motion detector (controls light & fan)

### Plug & Play

**Mobility Kit**  
Includes casters with fasteners

**Light**  
12V LED light bar with magnet  
570mm/pcs super light bar, 3500K, 12VDC

**Sprinkler**  
Pre-engineered knockout hole for 3rd party sprinkler installation

**Power Cord**  
10ft cord 120V/15Amp

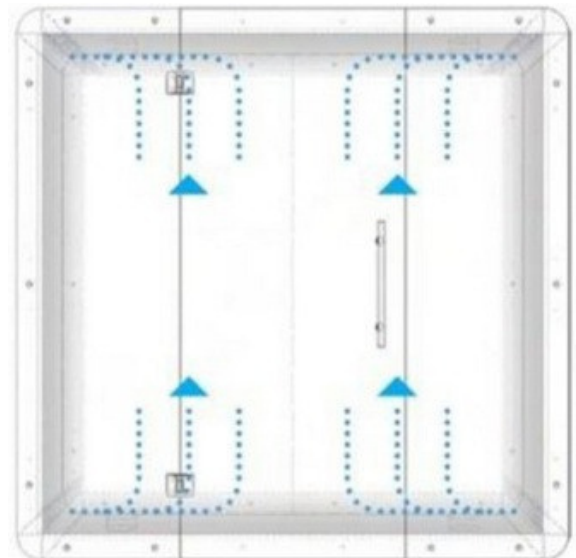

\*Air Flow Diagram





Because Privacy Matters



## Kubebooth Technical Data Sheet - Kwe Plus

### Extendable

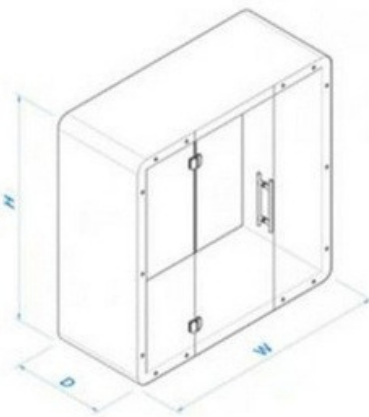

### Easy to Install

**Size Overall** - W: 88" - D: 48" - H: 88"  
**Inside** - W: 80" - D: 47" - H: 80"

**Weight**

1525 lbs/ 692 kg

**Glass**

10mm clear tempered  
Ceramic painted borders  
Door - H: 88" x W: 32"  
Rear Panels - H: 88" x W: 44"  
Front Side Panels - H: 88" x W: 28"

**Reversible Door**

Fully interchangeable left or right opening

**Worktop**

White or Black laminate wood worktop  
D shape L: 31" x W:24"  
Installed at an optimum height of 28"

**Felt**

Interior sound absorption panels 60% recyclable

**Options**

Seismic bracing  
One touch LCD control panel  
LCD TV mount bracing  
White glass board - W: 34" x L: 30"  
Personalized company branding  
Ethernet ports  
Bluetooth speaker  
Frosted film glass  
External fire extinguisher unit  
Smart lock  
Occupancy lights

### Moveable

**Acoustics**

NIC rating of 36 dB certified  
Noise cancellation technology

**Air Exchange**

100 complete air changes per hour

**Data Center**

UL approved  
1 USB A port, 1 USB C port  
2 Simplex outlets  
Motion detector (controls light & fan)

### Plug & Play

**Mobility Kit**

Includes casters with fasteners

**Light**

12V LED light bar with magnet  
570mm/pcs super light bar, 3500K, 12VDC

**Sprinkler**

Pre-engineered knockout hole for 3rd party sprinkler installation

**Power Cord**

10ft cord 120V/15Amp

**Wall Construction**

Galvanized steel frames  
Sound insulation in all cavities

**Finishes**

D-pull handle  
TFL surface  
CARB certified  
(zero/low formaldehyde emissions)  
Aluminum hardware painted

**Carpet**

Shaw Commercial Philadelphia  
Ayers Hall II or equal  
Solution dyed polypropylene 28 oz, 10 gauge  
GreenGuard certified GLP8472  
<450 NBS smoke

**Floor Ceiling**

Substructure-rated MDF on unitized steel base.

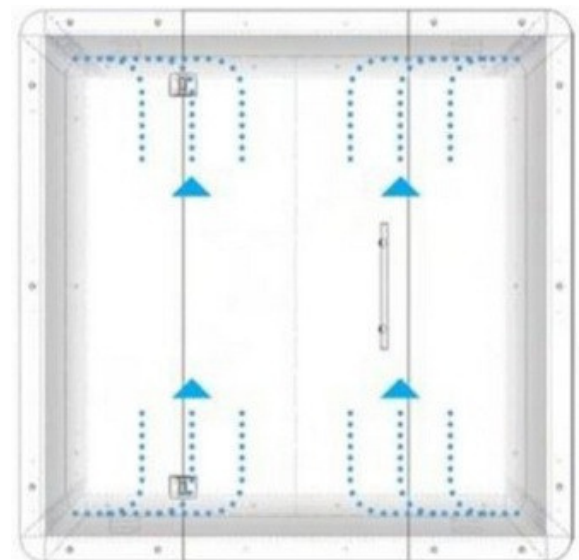

\*Air Flow Diagram





Because Privacy Matters



# Kubebooth Technical Data Sheet - Kteam 4

## Extendable

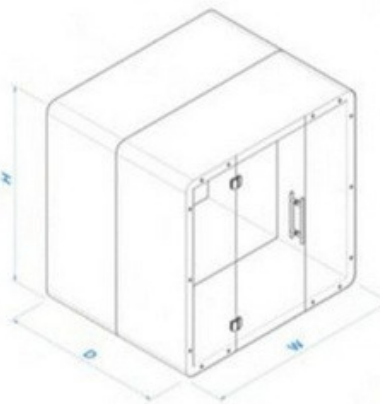

## Easy to Install

## Moveable

## Plug & Play

**Size Overall** - W: 88" - D: 73" - H: 88"  
**Inside** - W: 80" - D: 72" - H: 80"

**Weight**  
1800 lbs/816 kg

**Glass**  
10mm clear tempered  
Ceramic painted borders  
Door - H: 88" x W: 32"  
Rear Panels - H: 88" x W: 44"  
Front Side Panels - H: 88" x W: 28"

**Reversible Door**  
Fully interchangeable left or right opening

**Worktop**  
White or Black laminate wood worktop  
D Shape L: 45" x W: 24"  
Installed at an optimum height of 28"

**Felt**  
Interior sound absorption panels  
60% recyclable

**Options**  
Seismic bracing  
One touch LCD control panel  
LCD TV mount bracing  
White glass board - W: 34" x L: 30"  
Personalized company branding  
Ethernet ports  
Bluetooth speaker  
Frosted film glass  
External fire extinguisher unit  
Smart lock  
Occupancy lights

**Acoustics**  
NIC rating of 36 dB certified  
Noise cancellation technology

**Air Exchange**  
100 complete air changes per hour

**Data Center**  
UL approved  
1 USB A port, 1 USB C port  
2 Simplex outlets  
Motion detector (controls light & fan)

**Mobility Kit**  
Includes casters with fasteners

**Light**  
12V LED light bar with magnet  
570mm/pcs super light bar, 3500K, 12VDC

**Sprinkler**  
Pre-engineered knockout hole for 3rd party sprinkler installation

**Power Cord**  
10ft cord 120V/15Amp

**Wall Construction**  
Galvanized steel frames  
Sound insulation in all cavities

**Finishes**  
D-pull handle  
TFL surface  
CARB certified  
(zero/low formaldehyde emissions)  
Aluminum hardware painted

**Carpet**  
Shaw Commercial Philadelphia Ayers Hall II or equal  
Solution dyed polypropylene 28 oz, 10 gauge  
GreenGuard certified GLP8472  
<450 NBS smoke

**Floor Ceiling**  
Substructure-rated MDF on unitized steel base.

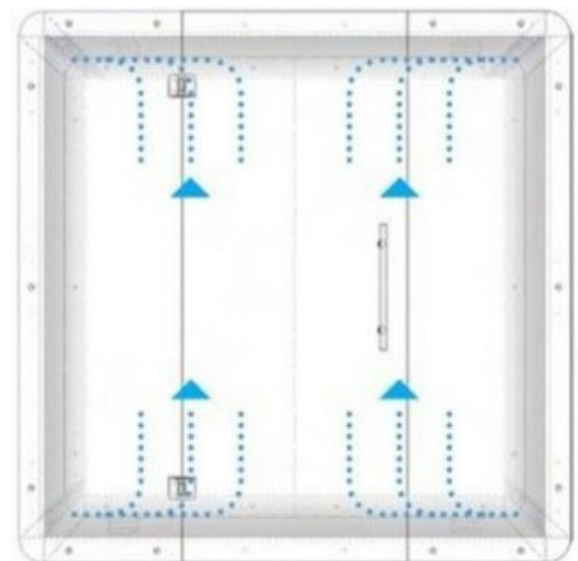

\*Air Flow Diagram





Because Privacy Matters



# Kubebooth Technical Data Sheet - Kteam 6

## Extendable

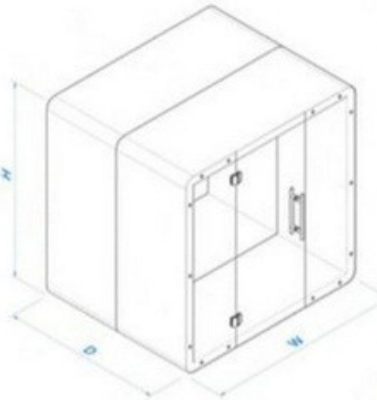

## Easy to Install

**Size**  
Overall - W: 88" - D: 109" - H: 88"  
Inside - W: 80" - D: 108" - H: 80"

**Weight**  
2400 lbs/1089 kg

**Glass**  
10mm clear tempered  
Ceramic painted borders  
Door - H: 88" x W: 32"  
Rear Panels - H: 88" x W: 44"  
Front Side Panels - H: 88" x W: 28"

**Reversible Door**  
Fully interchangeable left or right opening

**Worktop**  
White or Black laminate wood worktop  
D Shape

**Felt**  
Interior sound absorption panels  
60% recyclable

**Options**  
Seismic bracing  
One touch LCD control panel  
LCD TV mount bracing  
White glass board - W: 34" x L: 30"  
Personalized company branding  
Ethernet ports  
Bluetooth speaker  
Frosted film glass  
External fire extinguisher unit  
Smart lock  
Occupancy lights

## Moveable

**Acoustics**  
NIC rating of 36 dB certified  
Noise cancellation technology

**Air Exchange**  
100 complete air changes per hour

**Data Center**  
UL approved  
1 USB A port, 1 USB C port  
2 Simplex outlets  
Motion detector (controls light & fan)

## Plug & Play

**Mobility Kit**  
Includes casters with fasteners

**Light**  
12V LED light bar with magnet  
570mm/pcs super light bar, 3500K, 12VDC

**Sprinkler**  
Pre-engineered knockout hole for 3rd party sprinkler installation

**Power Cord**  
10ft cord 120V/15Amp

**Wall Construction**  
Galvanized steel frames  
Sound insulation in all cavities

**Finishes**  
D-pull handle  
TFL surface  
CARB certified  
(zero/low formaldehyde emissions)  
Aluminum hardware painted

**Carpet**  
Shaw Commercial Philadelphia  
Ayers Hall II or equal  
Solution dyed polypropylene 28 oz, 10 gauge  
GreenGuard certified GLP8472  
<450 NBS smoke

**Floor Ceiling**  
Substructure-rated MDF on unitized steel base.

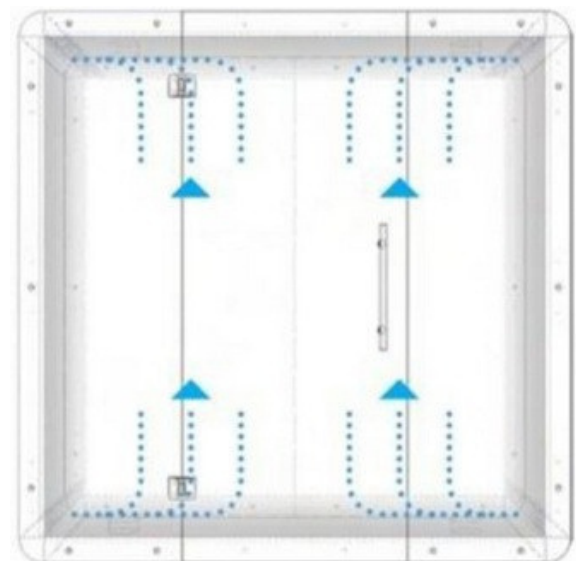

\*Air Flow Diagram







Because Privacy Matters



## Kubebooth Technical Data Sheet - Kteam 8

### Easy to Install

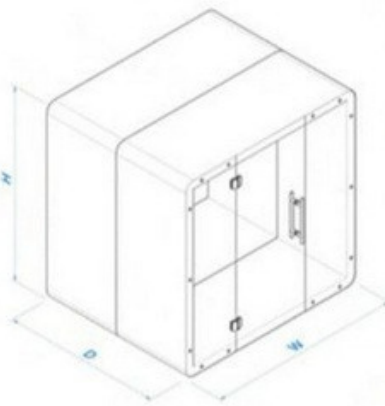

**Size**  
Overall - W: 88" - D: 145" - H: 88"  
Inside - W: 80" - D: 144" - H: 80"

**Weight**  
3000 lbs/1361 kg

**Glass** 10mm clear tempered  
Ceramic painted borders  
Door - H: 88" x W: 32"  
Rear Panels - H: 88" x W: 44"  
Front Side Panels - H: 88" x W: 28"

### Moveable

**Reversible Door** Fully interchangeable left or right opening

**Worktop**  
White or Black laminate wood worktop  
D Shape

**Felt**  
Interior sound absorption panels  
60% recyclable

**Options**  
Seismic bracing  
One touch LCD control panel  
LCD TV mount bracing  
White glass board - W: 34" x L: 30"  
Personalized company branding  
Ethernet ports  
Bluetooth speaker  
Frosted film glass  
External fire extinguisher unit  
Smart lock  
Occupancy lights

### Plug & Play

**Acoustics**  
NIC rating of 36 dB certified  
Noise cancellation technology

**Air Exchange**  
100 complete air changes per hour

**Data Center**  
UL approved  
1 USB A port, 1 USB C port  
2 Simplex outlets  
Motion detector (controls light & fan)

**Mobility Kit**  
Includes casters with fasteners

**Light**  
12V LED light bar with magnet  
570mm/pcs super light bar, 3500K, 12VDC

**Sprinkler**  
Pre-engineered knockout hole for 3rd party sprinkler installation

**Power Cord**  
10ft cord 120V/15Amp

**Wall Construction**  
Galvanized steel frames  
Sound insulation in all cavities

**Finishes**  
D-pull handle  
TFL surface  
CARB certified  
(zero/low formaldehyde emissions)  
Aluminum hardware painted

**Carpet**  
Shaw Commercial Philadelphia  
Ayers Hall II or equal  
Solution dyed polypropylene 28 oz, 10 gauge  
GreenGuard certified GLP8472  
<450 NBS smoke

**Floor Ceiling**  
Substructure-rated MDF on unitized steel base.

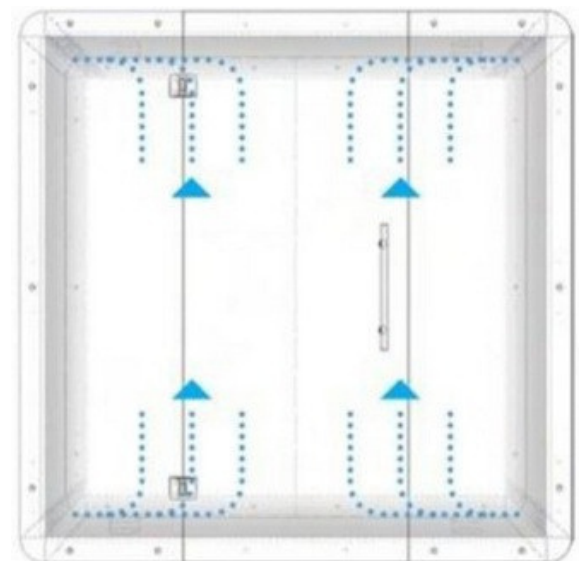

\*Air Flow Diagram





Because Privacy Matters



## Kubebooth Technical Data Sheet - KSelfi Floorless



### Easy to Install

**Size**  
Overall - W: 44" - D: 37" - H: 88"  
Inside - W: 36" - D: 36" - H: 84"

**Weight**  
750 lbs/340 kg

**Glass**  
10mm clear tempered  
Door - H: 88" x W: 32"  
Rear Panel - H: 88" x W: 44"  
Front Side Panel - H: 88" x W: 12"

### Plug & Play

**Acoustics**  
Class A noise reduction

**Air Exchange**  
100 complete air changes per hour

**Data Center**  
UL approved  
1 USB A port, 1 USB C port  
2 Simplex outlets  
Motion detector (controls light & fan)

**Light**  
12V LED light bar with magnet  
570mm/pcs super light bar, 3500K, 12VDC

**Sprinkler**  
Pre-engineered knockout hole for 3rd party sprinkler installation

**Power Cord**  
10ft cord 120V/15Amp

**Wall Construction**  
Galvanized steel frames  
Sound insulation in all cavities

**Door Lock**  
Patch fit low noise- silent latch

**Finishes**  
TFL surface  
CARB certified (zero/low formaldehyde emissions)  
Aluminum hardware painted

**Reversible Door**  
Fully interchangeable left or right opening

**Worktop**  
White or Black laminate wood worktop  
W: 20" x L: 12"  
Installed at an optimum height of 40"

**Felt**  
Interior sound absorption panels  
60% recyclable

**Options**  
Seismic bracing  
One touch LCD control panel LCD TV mount  
bracing White glass board - W: 34" x L: 30"  
Personalized company branding  
Ethernet ports  
Bluetooth speaker  
Frosted film glass  
External fire extinguisher unit  
Occupancy lights

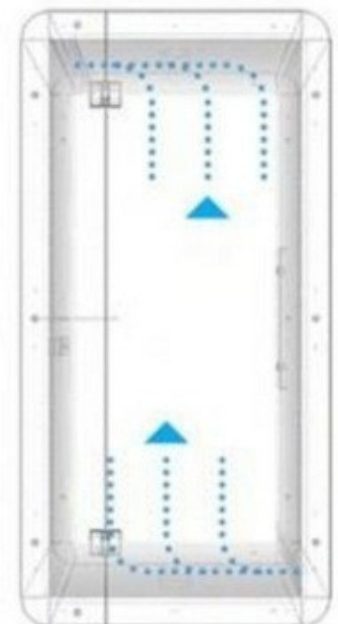

\*Air Flow Diagram

**Note: For your safety and optimal performance, this phone booth must be securely drilled to the floor during installation.**





Because Privacy Matters



## Kubebooth Technical Data Sheet - KSelfi Plus Floorless

### Easy to Install

### Plug & Play



**Size Overall** - W: 56" - D: 48" - H: 88"  
**Inside** - W: 48" - D: 47" - H: 84"

**Weight**  
950 lbs/431 kg

**Glass**  
10mm clear tempered  
Door - H: 88" x W: 32"

Rear Panel - H: 88" x W: 44"  
Front Side Panels - H: 88" x W: 12"  
\*Panel includes 2 piece glass

**Acoustics**  
Class A noise reduction

**Air Exchange**  
100 complete air changes per hour

**Data Center**  
UL approved  
1 USB A port, 1 USB C port,  
2 Simplex outlets  
Motion detector (controls light & fan)

**Light**  
12V LED light bar with magnet  
570mm/pcs super light bar, 3500K,  
12VDC

**Sprinkler**  
Pre-engineered knockout hole for 3rd party sprinkler installation

**Door Lock**  
Patch fit low noise- silent latch

**Reversible Door**  
Fully interchangeable left or right opening

**Felt**  
Interior sound absorption panels  
60% recyclable

**Options**  
Seismic bracing  
One touch LCD control panel  
LCD TV mount bracing  
White glass board - W: 34" x L: 30"  
Personalized company branding  
Ethernet ports  
Bluetooth speaker  
Frosted film glass  
External fire extinguisher unit  
Occupancy lights

**Power Cord**  
10ft cord 120V/15Amp

**Wall Construction**  
Galvanized steel frames  
Sound insulation in all cavities

**Finishes**  
TFL surface CARB certified (zero/low formaldehyde emissions) Aluminum hardware painted

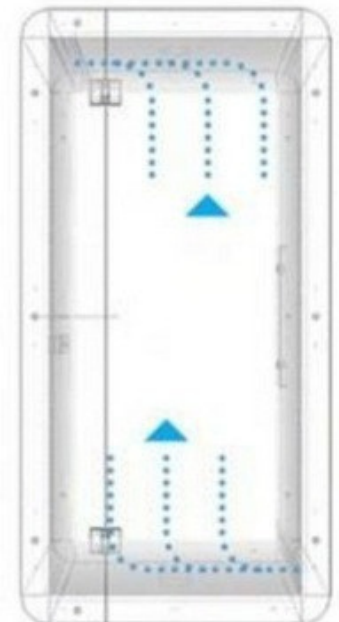

\*Air Flow Diagram

**Note: For your safety and optimal performance, this pod must be securely drilled to the floor during installation.**





Because Privacy Matters



# Kubebooth Technical Data Sheet - Kme Floorless

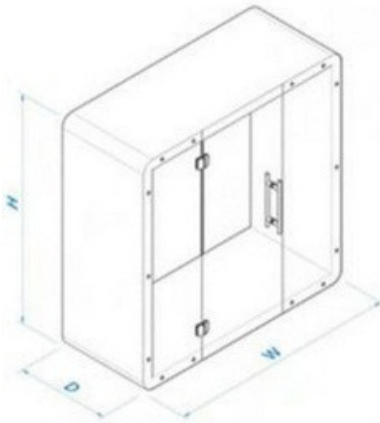

## Easy to Install

**Size**  
Overall - W: 88" - D: 37" - H: 88"  
Inside - W: 80" - D: 36" - H: 84"

**Weight**  
1100 lbs/500 kg

**Glass**  
10mm clear tempered  
Door - H: 88" x W: 32"  
Rear Panel - H: 88" x W: 44"  
Front Side Panels - H: 88" x W: 28"

## Plug & Play

**Acoustics**  
Class A noise reduction

**Air Exchange**  
100 complete air changes per hour

**Data Center**  
UL approved  
1 USB A port, 1 USB C port  
2 Simplex outlets  
Motion detector (controls light & fan)

**Light**  
12V LED light bar with magnet  
570mm/pcs super light bar, 3500K, 12VDC

**Sprinkler**  
Pre-engineered knockout hole for 3rd party sprinkler installation

**Power Cord**  
10ft cord 120V/15Amp

### Wall Construction

Galvanized steel frames  
Sound insulation in all cavities

### Door Lock

Patch fit low noise- silent latch

### Finishes

TFL surface  
CARB certified  
(zero/low formaldehyde emissions)  
Aluminum hardware painted

### Reversible Door

Fully interchangeable left or right opening

### Felt

Interior sound absorption panels  
60% recyclable

### Options

Seismic bracing  
One touch LCD control panel  
LCD TV mount bracing  
White glass board - W: 34" x L: 30"  
Personalized company branding  
Ethernet ports  
Bluetooth speaker  
Frosted film glass  
External fire extinguisher unit  
Occupancy lights

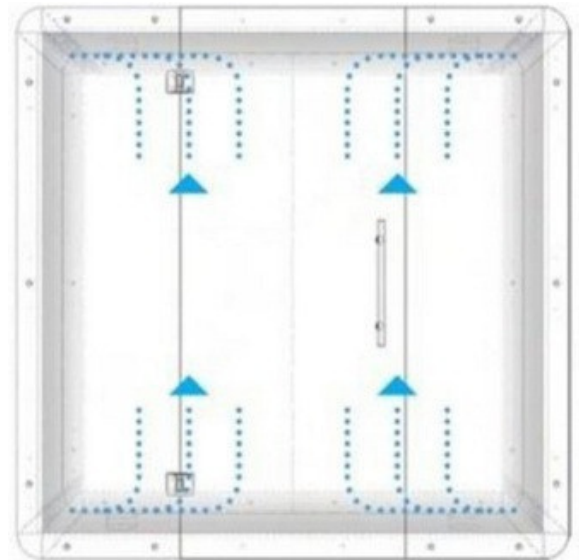

\*Air Flow Diagram

**Note: This privacy pod requires drilling to the floor as part of standard installation to ensure structural stability and user safety.**





Because Privacy Matters



## Kubebooth Technical Data Sheet - Kme Plus Floorless

### Easy to Install

Size Overall - W: 88" - D: 48" - H: 88"  
Inside - W: 80" - D: 47" - H: 84"

Weight  
1150 lbs/527 kg

Glass  
10mm clear tempered  
Door - H: 88" x W: 32"  
Rear Panel - H: 88" x W: 44"  
Front Side Panels - H: 88" x W: 28"

### Plug & Play

Acoustics  
Class A noise reduction

Air Exchange  
100 complete air changes per hour

Data Center  
UL approved  
1 USB A port, 1 USB C port  
2 Simplex outlets  
Motion detector (controls light & fan)

Light  
12V LED light bar with magnet  
570mm/pcs super light bar, 3500K, 12VDC

Sprinkler  
Pre-engineered knockout hole for 3rd party sprinkler installation

Power Cord  
10ft cord 120V/15Amp

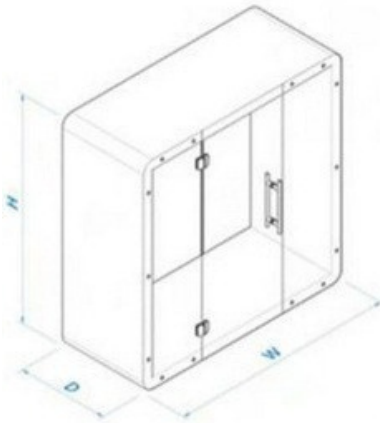

**Wall Construction**  
Galvanized steel frames  
Sound insulation in all cavities

**Door Lock**  
Patch fit low noise- silent latch  
**Finishes**

TFL surface  
CARB certified (zero/low formaldehyde emissions)  
Aluminum hardware painted

**Reversible Door**  
Fully interchangeable left or right opening

**Felt**  
Interior sound absorption panels  
60% recyclable

**Options**  
Seismic bracing  
One touch LCD control panel  
LCD TV mount bracing  
White glass board - W: 34" x L: 30"  
Personalized company branding  
Ethernet ports  
Bluetooth speaker  
Frosted film glass  
External fire extinguisher unit  
Occupancy lights

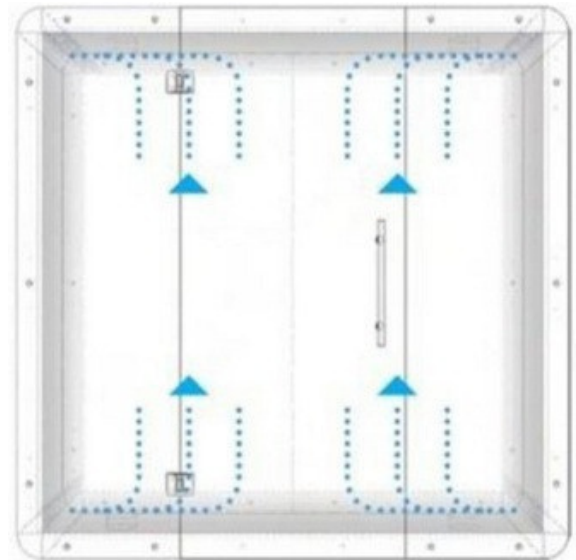

\*Air Flow Diagram

**Note: This privacy pod requires drilling to the floor as part of standard installation to ensure structural stability and user safety.**





Because Privacy Matters



# Kubebooth Technical Data Sheet - Kwe Floorless

## Extendable

## Easy to Install

## Plug & Play

**Size Overall** - W: 88" - D: 37" - H: 88"  
**Inside** - W: 80" - D: 36" - H: 84"

**Weight**  
1100 lbs/500 kg

**Glass**  
10mm clear tempered  
Door - H: 88" x W: 32"  
Rear Panels - H: 88" x W: 44"  
Front Side Panels - H: 88" x W: 28"

**Reversible Door**  
Fully interchangeable left or right opening

**Worktop**  
White or Black laminate wood worktop  
D shape L: 24" x W: 24"  
Installed at an optimum height of 28"

**Felt**  
Interior sound absorption panels  
60% recyclable

**Options**  
Seismic bracing  
One touch LCD control panel  
LCD TV mount bracing  
White glass board - W: 34" x L: 30"  
Personalized company branding  
Ethernet ports  
Bluetooth speaker  
Frosted film glass  
External fire extinguisher unit  
Door lock  
Occupancy lights

**Acoustics**  
Class A noise reduction

**Air Exchange**  
100 complete air changes per hour

**Data Center**  
UL approved  
1 USB A port, 1 USB C port  
2 Simplex outlets  
Motion detector (controls light & fan)

**Light**  
12V LED light bar with magnet  
570mm/pcs super light bar, 3500K, 12VDC

**Sprinkler** Pre-engineered knockout hole for 3rd party sprinkler installation  
**Power Cord**  
10ft cord 120V/15Amp



**Door Lock**  
Patch fit low noise- silent latch

**Wall Construction**  
Galvanized steel frames  
Sound insulation in all cavities

**Finishes**  
TFL surface  
CARB certified  
(zero/low formaldehyde emissions)  
Aluminum hardware painted

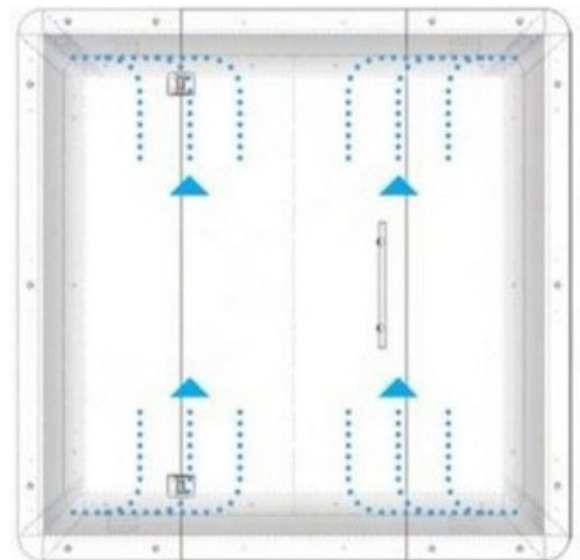

\*Air Flow Diagram

**Note: This meeting pod must be drilled to the floor to maintain structural integrity and ensure user safety.**





Because Privacy Matters



# Kubebooth Technical Data Sheet - Kwe Plus Floorless

## Extendable

## Easy to Install

## Plug & Play

**Size Overall** - W: 88" - D: 48" - H: 88"  
**Inside** - W: 80" - D: 47" - H: 84"

**Weight**  
1150 lbs/527 kg

**Glass**  
10mm clear tempered  
Door - H: 88" x W: 32"  
Rear Panels - H: 88" x W: 44"  
Front Side Panels - H: 88" x W: 28"

**Acoustics**  
Class A noise reduction

**Air Exchange**  
100 complete air changes per hour

**Data Center**  
UL approved  
1 USB A port, 1 USB C port  
2 Simplex outlets  
Motion detector (controls light & fan)

**Light**  
12V LED light bar with magnet  
570mm/pcs super light bar, 3500K, 12VDC

**Sprinkler** Pre-engineered knockout hole for 3rd party sprinkler installation  
**Power Cord**  
10ft cord 120V/15Amp

**Reversible Door** Fully interchangeable left or right opening

**Worktop**  
White or Black laminate wood worktop  
D shape L: 31" x W:24"  
Installed at an optimum height of 28"

**Options** Seismic bracing One touch LCD control panel  
LCD TV mount bracing  
White glass board - W: 34" x L: 30"  
Personalized company branding  
Ethernet ports  
Bluetooth speaker  
Frosted film glass  
External fire extinguisher unit  
Door lock  
Occupancy lights

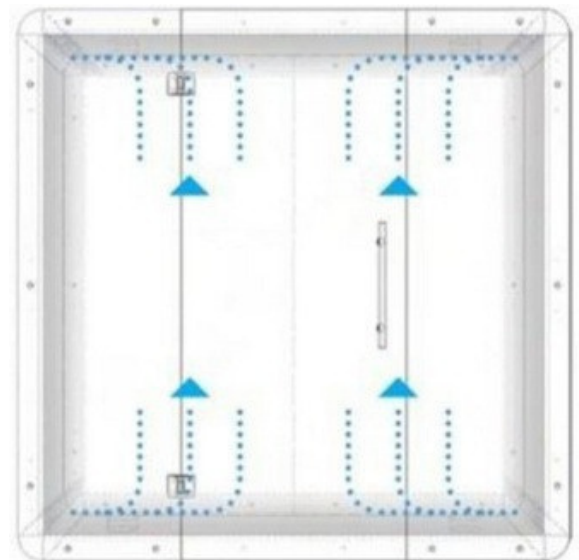

\*Air Flow Diagram

**Door Lock**  
Patch fit low noise- silent latch

**Wall Construction**  
Galvanized steel frames  
Sound insulation in all cavities

**Felt**  
Interior sound absorption panels  
60% recyclable

**Finishes**  
TFL surface  
CARB certified (zero/low formaldehyde emissions)  
Aluminum hardware painted

**Note: This meeting pod must be drilled to the floor to maintain structural integrity and ensure user safety.**





Because Privacy Matters



# Kubebooth Technical Data Sheet - Kteam 4 Floorless

## Extendable

## Easy to Install

## Plug & Play

### Size

Overall - W: 88" - D: 73" - H: 88"  
Inside - W: 80" - D: 72" - H: 84"

### Weight

1600 lbs/726 kg

### Glass 10mm clear tempered

Door - H: 88" x W: 32"  
Rear Panels - H: 88" x W: 44"  
Front Side Panels - H: 88" x W: 28"

### Acoustics

Class A noise reduction

### Air Exchange

100 complete air changes per hour

### Data Center

UL approved  
1 USB A port, 1 USB C port  
2 Simplex outlets  
Motion detector (controls light & fan)

### Light

12V LED light bar with magnet  
570mm/pcs super light bar, 3500K, 12VDC

### Sprinkler

Pre-engineered knockout hole for 3rd party sprinkler installation

### Power Cord

10ft cord 120V/15Amp

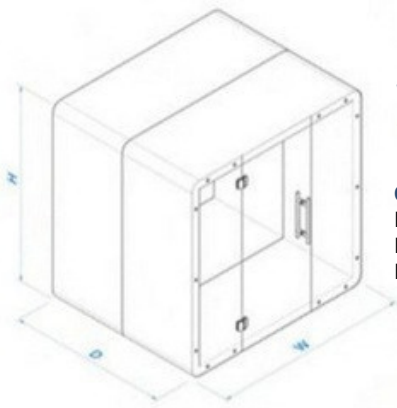

**Reversible Door** Fully interchangeable left or right opening

### Worktop

White or Black Laminate wood D shape  
worktop L: 45" x W: 24"  
Installed at an optimum height of 28"

### Options

- Seismic bracing
- One touch LCD control panel
- LCD TV mount bracing
- White glass board - W: 34" x L: 30"
- Personalized company branding
- Ethernet ports
- Bluetooth speaker
- Frosted film glass
- External fire extinguisher unit
- Door lock
- Occupancy lights

### Wall Construction

Galvanized steel frames  
Sound insulation in all cavities

### Finishes

TFL surface CARB certified  
(zero/low formaldehyde emissions)  
Aluminum hardware painted

### Felt

Interior sound absorption panels  
60% recyclable

### Door Lock

Patch fit low noise- silent latch

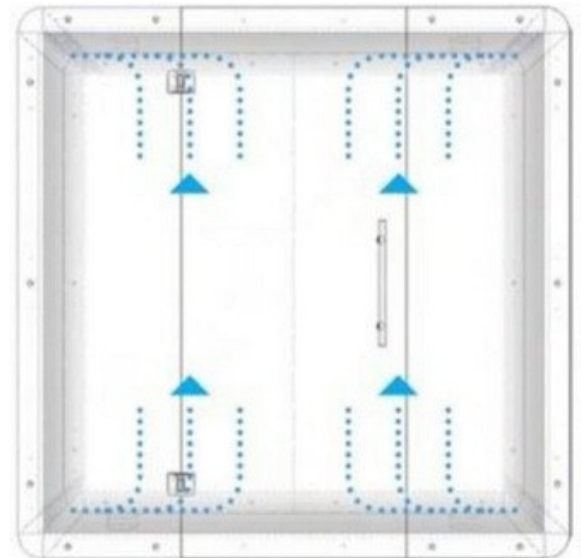

\*Air Flow Diagram

**Note: This collaborative pod requires drilling to the floor during installation to ensure stability and safety for multiple users.**







Because Privacy Matters



## Kubebooth Technical Data Sheet - Kteam 6 Floorless

### Extendable

### Easy to Install

### Plug & Play

**Size**  
Overall - W: 88" - D: 109" - H: 88"  
Inside - W: 80" - D: 108" - H: 84"

**Weight**  
2100 lbs/953 kg

**Glass** 10mm clear tempered  
Door - H: 88" x W: 32"  
Rear Panels - H: 88" x W: 44"  
Front Side Panels - H: 88" x W: 28"

**Worktop**  
Black or White Laminate wood D shape worktop

**Felt**  
Interior sound absorption panels  
60% recyclable

**Options**  
Seismic bracing  
One touch LCD control panel  
LCD TV mount bracing  
White glass board - W: 34" x L: 30"  
Personalized company branding  
Ethernet ports  
Bluetooth speaker  
Frosted film glass  
External fire extinguisher unit  
Door lock  
Occupancy lights

**Acoustics**  
Class A noise reduction

**Air Exchange**  
100 complete air changes per hour

**Data Center**  
UL approved  
1 USB A port, 1 USB C port  
2 Simplex outlets  
Motion detector (controls light & fan)

**Light**  
12V LED light bar with magnet  
570mm/pcs super light bar, 3500K, 12VDC

**Sprinkler**  
Pre-engineered knockout hole for 3rd party sprinkler installation

**Power Cord**  
10ft cord 120V/15Amp

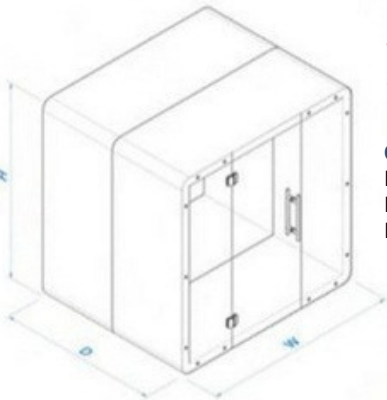

**Wall Construction**  
Galvanized steel frames  
Sound insulation in all cavities

**Finishes**  
TFL surface  
CARB certified  
(zero/low formaldehyde emissions)  
Aluminum hardware painted

**Door Lock**  
Patch fit low noise- silent latch

**Reversible Door**  
Fully interchangeable left or right opening

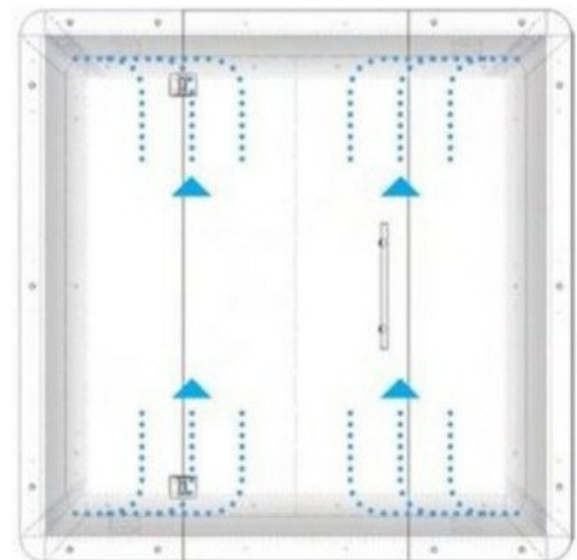

\*Air Flow Diagram

**Note: This collaborative pod requires drilling to the floor during installation to ensure stability and safety for multiple users.**





Because Privacy Matters



## Kubebooth Technical Data Sheet - Kteam 8 Floorless

### Easy to Install

### Plug & Play

#### Size

Overall - W: 88" - D: 145" - H: 88"  
Inside - W: 80" - D: 144" - H: 84"

#### Weight

2600 lbs/1180 kg

#### Glass 10mm clear tempered

Door - H: 88" x W: 32"  
Rear Panels - H: 88" x W: 44"  
Front Side Panels - H: 88" x W: 28"

#### Acoustics

Class A noise reduction

#### Air Exchange

100 complete air changes per hour

#### Data Center

UL approved  
1 USB A port, 1 USB C port  
2 Simplex outlets  
Motion detector (controls light & fan)

#### Light

12V LED light bar with magnet  
570mm/pcs super light bar, 3500K,  
12VDC

#### Sprinkler

Pre-engineered knockout hole for 3rd party sprinkler installation

#### Power Cord

10ft cord 120V/15Amp

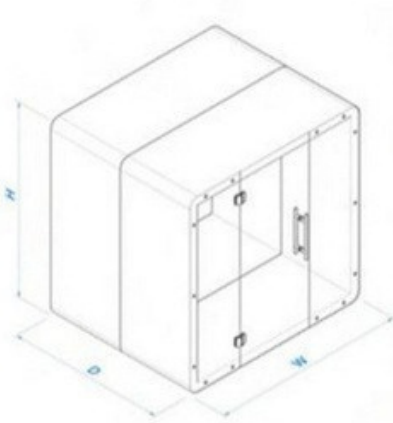

#### Reversible Door

Fully interchangeable left or right opening

#### Worktop

Black or White laminate wood D shape worktop

#### Felt

Interior sound absorption panels  
60% recyclable

#### Options

Seismic bracing  
One touch LCD control panel  
LCD TV mount bracing  
White glass board - W: 34" x L: 30"  
Personalized company branding  
Ethernet ports  
Bluetooth speaker  
Frosted film glass  
External fire extinguisher unit  
Door lock  
Occupancy lights

#### Wall Construction

Galvanized steel frames  
Sound insulation in all cavities

#### Finishes

TFL surface  
CARB certified  
(zero/low formaldehyde emissions)  
Aluminum hardware painted

#### Door Lock

Patch fit low noise- silent latch

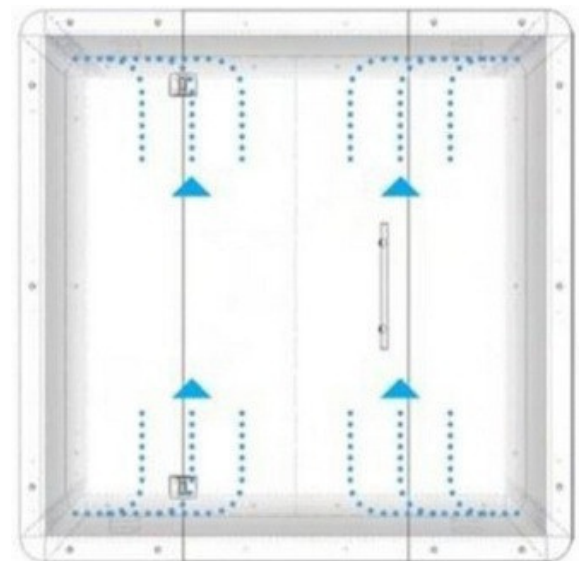

\*Air Flow Diagram

**Note: This collaborative pod requires drilling to the floor during installation to ensure stability and safety for multiple users.**

